

warm gewalzt • laminati a caldo • rolled with heat



Schmiedebronze
bronzò da forgia
bronze forged



ART.	MAT.	KG
20514	54x9 mm	1,61

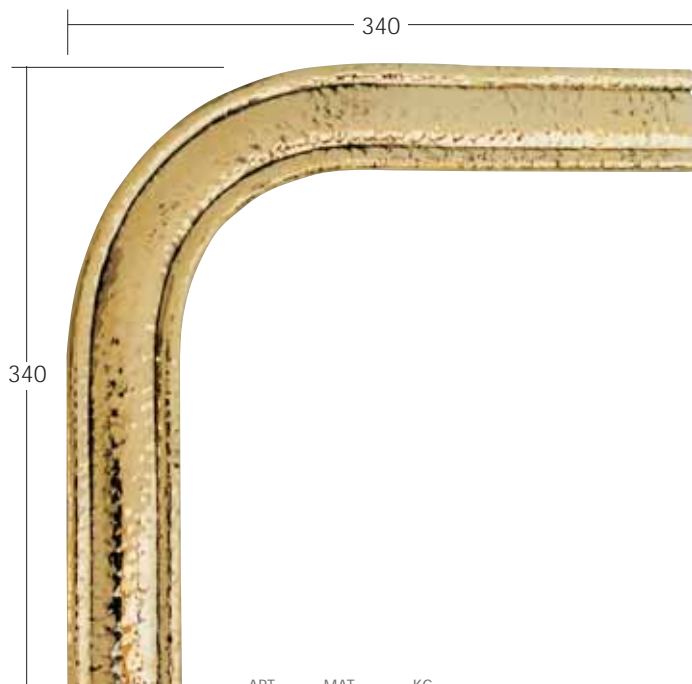

ART.	MAT.	KG
20516	54x9 mm	1,61

ART.	MAT.	KG
20522	54x9 mm	1,85
20532	42x8 mm	1,38



ART.	MAT.	KG
20520	54x9x3000 mm	3,09
20530	42x8x3000 mm	2,30



Schmiedebronze
bronzio da forgia
bronze forged



ART.	MAT.	KG
20524	54x9 mm	1,85
20534	42x8 mm	1,38

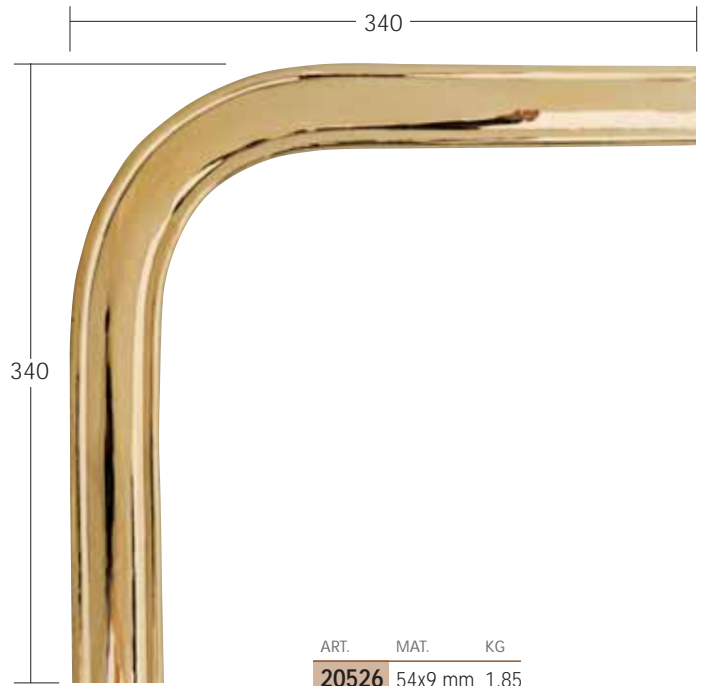

ART.	MAT.	KG
20526	54x9 mm	1,85
20536	42x8 mm	1,38

warm gewalzt • laminati a caldo • rolled with heat





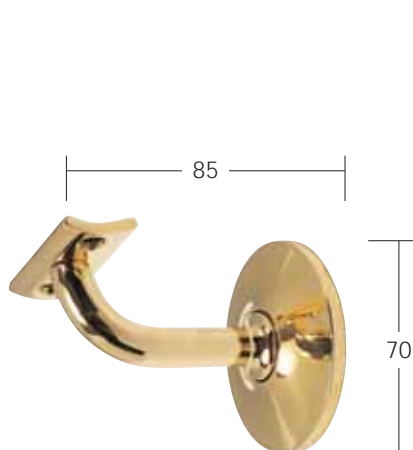

ART.	FÜR ROHR PER TUBE FOR TUBE	KG
22411	Ø33,7	0,22
22412	Ø42,4	0,23



ART.	FÜR ROHR PER TUBE FOR TUBE	KG
22421	Ø33,7	0,25
22422	Ø42,4	0,28



ART.	FÜR ROHR PER TUBE FOR TUBE	KG
22431	Ø33,7	0,25
22432	Ø42,4	0,28

Kugelgelenke - giunti sferici - ball-and-socket joints



ART.	FÜR ROHR PER TUBE FOR TUBE	KG
22451	Ø33,7	0,23
22452	Ø42,4	0,27



ART.	FÜR ROHR PER TUBE FOR TUBE	KG
22456	Ø33,7	0,32
22457	Ø42,4	0,37

Bodenrosetten piastrina di base base rosette



ART.	Ø D mm	KG
22460	12	0,28
22462	14	0,30
22464	25	0,35
22466	42,4	0,38

Eckkonsole mensola d'angolo edge console

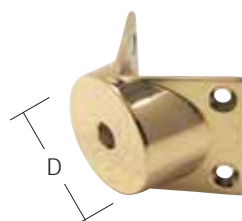

ART.	Ø D mm	KG
22470	42,4	0,08

Messing hochglanzpoliert und einbrennlackiert • ottone lucidato e verniciato a forno • brass highly polished, stove enamelled

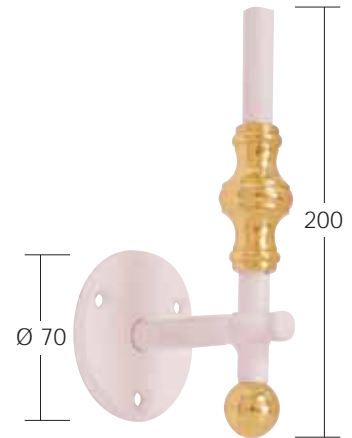
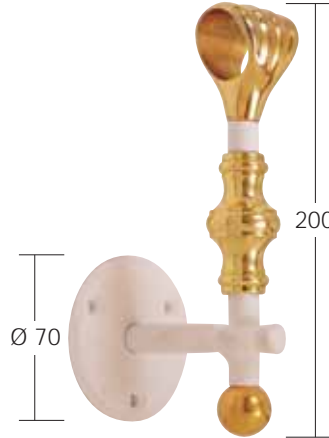

ART.	LOCH FORO HOLE	KG	GEWINDE FILETTO THREAD
22010	Ø30 mm	1,12	M 14

ART.	LOCH FORO HOLE	KG	GEWINDE FILETTO THREAD
22020	Ø30 mm	0,34	M 8

ART.	LOCH FORO HOLE	KG
22030	Ø30 mm	0,78

ART.	MAT.	KG
22040	Ø14 mm	0,78

Anwendungsbeispiele - esempi d'impiego - examples of application

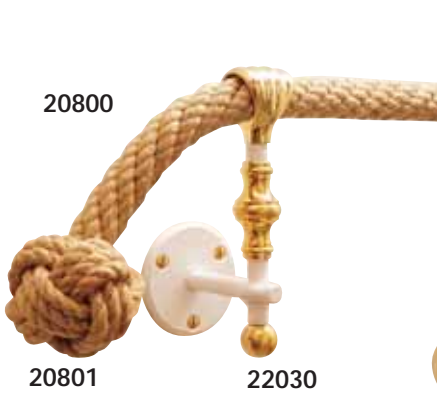
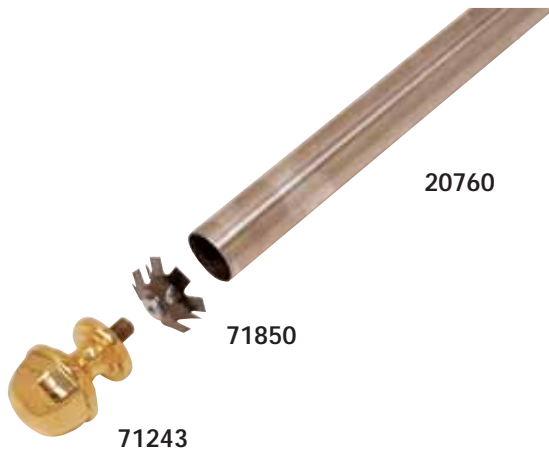



Hohlkugeln
sfere cave
hollow spheres

ART.	Ø mm	GEWINDE FILETTO THREAD	KG	vergoldet dorato gilder
70050	50	M 8	0,15	Art. 7G0050
70065	65	M 10	0,30	Art. 7G0065
70075	75	M 10	0,39	Art. 7G0075
70085	85	M 10	0,51	Art. 7G0085
70100	100	M 10	0,53	Art. 7G0100
70120	120	M 10	1,06	
70130	130	M 10	1,28	



Massivkugeln
sfere piene
hallow spheres

ART.	Ø mm	GEWINDE FILETTO THREAD	KG	vergoldet dorato gilder
70220	20	M 6	0,03	Art. 7G0220
70225	25	M 6	0,06	Art. 7G0225
70230	30	M 6	0,11	Art. 7G0230
70235	35	M 8	0,18	Art. 7G0235
70240	40	M 8	0,27	Art. 7G0240



Massivkugeln mit Sackloch
sfere piene con foro cieco
solid spheres with blind hole

ART.	MAT.	LOCH FOUR HOLE	vergoldet dorato gilder
71271	Ø20	Ø10,3	
71272	Ø20	Ø12,3	Art. 7G1272
71274	Ø20	Ø14,3	Art. 7G1274
71276	Ø25	Ø12,3	Art. 7G1276
71278	Ø25	Ø14,3	Art. 7G1278



Massivkugeln drehblank
sfere piene tornite
solid spheres bright late worked

ART.	Ø mm	GEWINDE FILETTO THREAD	KG
70410	10	M 4	0,01
70412	12	M 4	0,01
70414	14	M 5	0,01
70416	16	M 5	0,02
70420	20	M 6	0,03
70425	25	M 6	0,06
70430	30	M 6	0,11
70435	35	M 8	0,18
70440	40	M 8	0,27

Messing hochglanzpoliert und einbrennlackiert • ottone lucidato e verniciato a forno • brass highly polished, stove enamelled



ART.	ANSATZ SEDE LUG	GEWINDE FILETTO THREAD	KG
71030	Ø16 mm	M 6	0,05

ART.	ANSATZ SEDE LUG	GEWINDE FILETTO THREAD	KG
71050	Ø30 mm	M 10	0,19

ART.	ANSATZ SEDE LUG	GEWINDE FILETTO THREAD	KG
71058	Ø34 mm	M 10	0,27

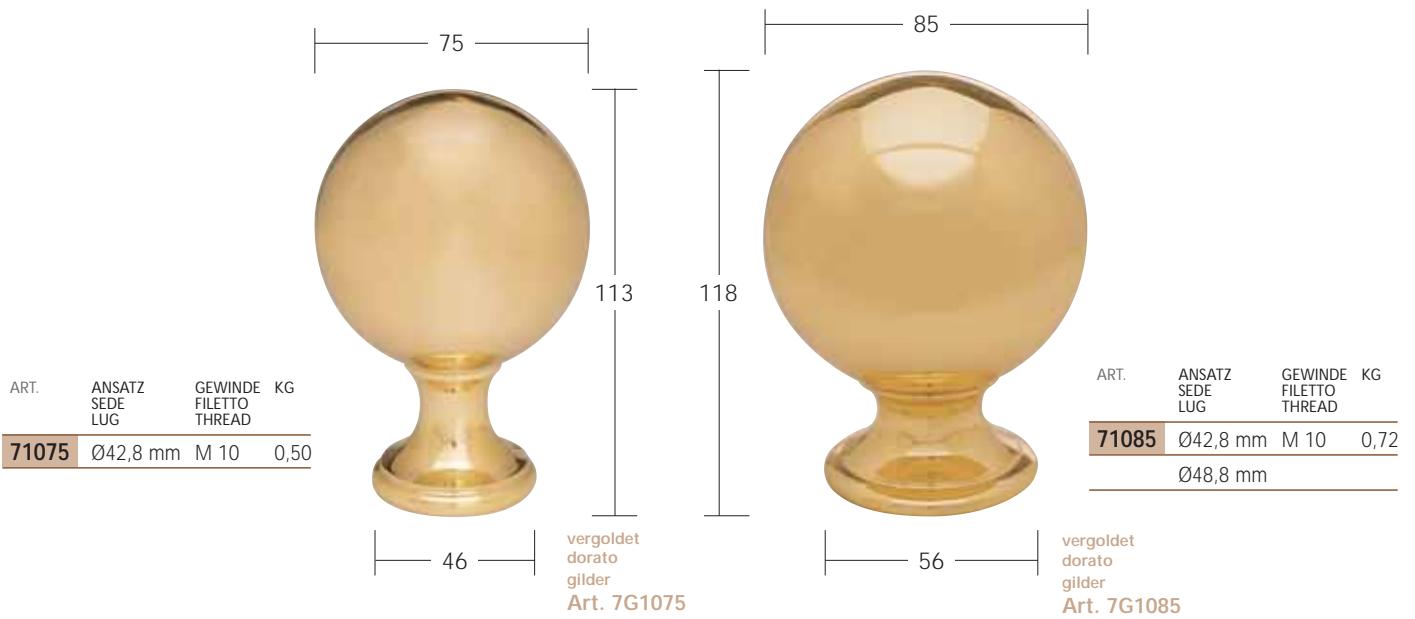

ART.	ANSATZ SEDE LUG	GEWINDE FILETTO THREAD	KG
71075	Ø42,8 mm	M 10	0,50

ART.	ANSATZ SEDE LUG	GEWINDE FILETTO THREAD	KG
71085	Ø42,8 mm	M 10	0,72
	Ø48,8 mm		





ART.	ANSATZ SEDE LUG	GEWINDE FILETTO THREAD	KG
71243	Ø30 mm	M 10	0,18



ART.	ANSATZ SEDE LUG	GEWINDE FILETTO THREAD	KG
71260	Ø30 mm	M 10	0,27



ART.	GEWINDE FILETTO THREAD	KG
71255	M 8	0,28



ART.	ANSATZ SEDE LUG	GEWINDE FILETTO THREAD	KG
71250	Ø26 mm	M 10	0,25

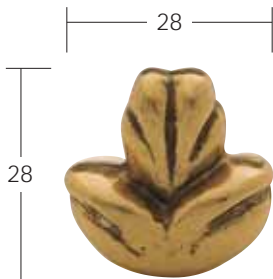

ART.	GEWINDE FILETTO THREAD	KG
71328	M 6	0,04



ART.	GEWINDE FILETTO THREAD	KG
71318	M 10x1 - M 6	0,04



ART.	GEWINDE FILETTO THREAD	KG
71330	M 10x1 - M 6	0,10



ART.	GEWINDE FILETTO THREAD	KG
71333	M 10	0,10



ART.	GEWINDE FILETTO THREAD	KG
71343	M 10	0,16

Messing hochglanzpoliert und einbrennlackiert • ottone lucidato e verniciato a forno • brass highly polished, stove enamelled



ART.	MAT.	LOCH FOUR HOLE	KG
71252	Ø20x16	Ø12,3	kg
71254	Ø20x16	Ø14,3	kg

vergoldet
dorato
gilder

Art. 7G1252
Art. 7G1254



ART.	ANSATZ SEDE LUG	KG
71432	Ø12 mm	0,02

vergoldet
dorato
gilder

Art. 7G1432



ART.	MAT.	LOCH FOUR HOLE	KG
71262	Ø20x16	Ø12,3	kg
71264	Ø20x16	Ø14,3	kg

vergoldet
dorato
gilder

Art. 7G1262
Art. 7G1264



Drehblank - torniti - lathe worked

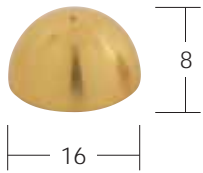

ART.	GEWINDE FILETTO THREAD	KG
71410	M 10x1 - M 6	0,01

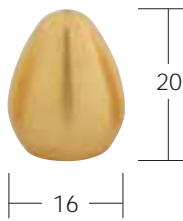

ART.	GEWINDE FILETTO THREAD	KG
71415	M 10x1 - M 6	0,01



ART.	GEWINDE FILETTO THREAD	KG
71420	M 10x1 - M 6	0,01



ART.	GEWINDE FILETTO THREAD	KG
71425	M 10x1 - M 6	0,01



ART.	GEWINDE FILETTO THREAD	KG
71430	M 10x1 - M 6	0,02



ART.	GEWINDE FILETTO THREAD	KG
71435	M 10x1 - M 6	0,05



ART.	GEWINDE FILETTO THREAD	KG
71440	M 10x1 - M 6	0,05



Reduzierung
riduzione
reduction

Gewindehülsen
bussole con filetto esterno
threaded coupling

Verschraubungseinsatz
inserto per fissaggio di finali
thread joint

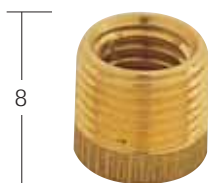

ART.	GEWINDE FILETTO THREAD
71820	M 10x1 - M 6

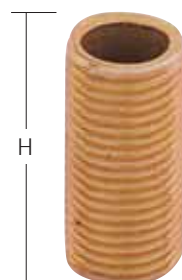

ART.	GEWINDE FILETTO THREAD	H
71830	M 10x1	20
71840	M 10x1	40



ART.	GEWINDE FILETTO THREAD	FÜR ROHRE PER TUBI FOR TUBES
71850	M 10	Ø30
71855	M 10	Ø42,4

Messing hochglanzpoliert und einbrennlackiert • ottone lucidato e verniciato a forno • brass highly polished, stove enamelled

Hutmutter
dadi ciechi con calotta sferica
cap nuts



ART.	GEWINDE FILETTO THREAD
71815	M 5
71816	M 6

Mutter
dado
hexagon nut



ART.	GEWINDE FILETTO THREAD
71810	M 10x1



ART.	LOCH FORO HOLE	KG
72170	Ø10	0,09

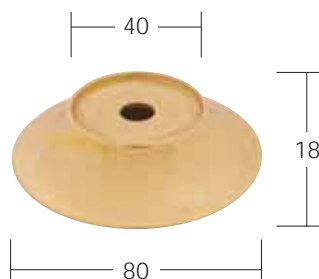

ART.	LOCH FORO HOLE	KG
72175	Ø10	0,10



ART.	LOCH FORO HOLE	KG
72180	Ø10	0,10

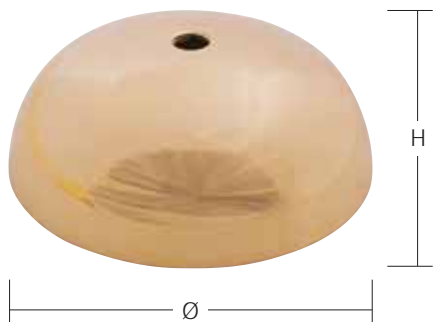

ART.	Ø mm	H mm	LOCH FORO HOLE	KG
72185	85	33	Ø10	0,16
72188	96	37	Ø10	0,30

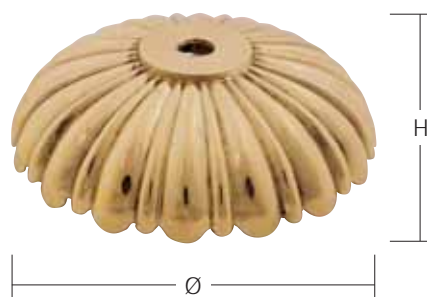

ART.	Ø mm	H mm	LOCH FORO HOLE	KG
72190	90	34	Ø10	0,16
72195	110	34	Ø10	0,25



ART.	LOCH FORO HOLE	KG
72245	Ø10	0,02

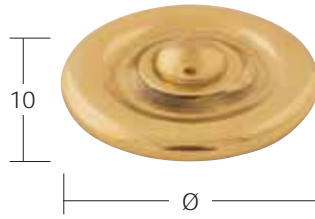

ART.	Ø mm	GEWINDE FILETTO THREAD	KG
72236	36	M 8	0,04
72250	50	M 8	0,06



ART.	LOCH FORO HOLE	KG
72258	Ø10	0,06



ART.	LOCH FORO HOLE	KG
72265	M 5	0,08



ART.	LOCH FORO HOLE	KG
72280	Ø10	0,06



ART.	LOCH FORO HOLE	KG
72290	Ø10	0,06

poliert und foliengeschützt - lucidate e protette con nylon - polished and foil coated



ART.	Ø mm	STÄRKE SPESSORE THICKNESS	KG
73033	33	4 mm	0,03
73040	40	4 mm	0,04
73050	50	4 mm	0,07
73060	60	4 mm	0,09
73070	70	4 mm	0,13
73080	80	6 mm	0,25
73100	100	6 mm	0,40



ART.	Ø mm	STÄRKE SPESSORE THICKNESS	KG
73255	55	4 mm	0,06
73292	92	4 mm	0,18

Messing hochglanzpoliert und einbrennlackiert • ottone lucidato e verniciato a forno • brass highly polished, stove enamelled



ART.	LOCH FORO HOLE	KG
74030	Ø14	0,16



ART.	GEWINDE FILETTO THREAD	KG
74032	Ø22,4	0,43
74035	Ø25,4	0,34



ART.	LOCH FOUR HOLE	KG
74038	Ø22,4	0,44
74040	Ø25,4	0,38



ART.	LOCH FORO HOLE	KG
74042	Ø25,4 mm	0,14



ART.	LOCH FORO HOLE	KG
74045	Ø12 mm	0,34



ART.	LOCH FORO HOLE	KG
74055	Ø25,4 mm	0,67



ART.	LOCH FORO HOLE	KG
74060	Ø25,4 mm	0,28



vergoldet
dorato
gilder
7G5030

ART.	LOCH FORO HOLE	KG
75030	Ø12,2 mm	0,18



ART.	LOCH FORO HOLE	KG
75035	Ø16,2 mm	0,18



vergoldet
dorato
gilder
7G5020

ART.	LOCH FORO HOLE	KG
75020	Ø12,2 mm	0,63



vergoldet
dorato
gilder
7G5025

ART.	LOCH FORO HOLE	KG
75025	Ø12,2 mm	0,09



ART.	LOCH FORO HOLE	KG
75040	Ø14,2 mm	0,14

ART.	LOCH FORO HOLE	KG
75045	Ø11 mm	0,16



ART.	LOCH FORO HOLE	KG
75055	Ø12 mm	0,16



ART.	LOCH FORO HOLE	KG
75060	Ø16,2 mm	0,30

Messing hochglanzpoliert und einbrennlackiert • ottone lucidato e verniciato a forno • brass highly polished, stove enamelled



ART.	LOCH FORO HOLE	KG
75125	Ø35 Ø12,2	
75130	Ø40 Ø14,2	



ART.	LOCH FORO HOLE	KG
75135	Ø8,5 mm 0,16	

vergoldet
dorato
gilder
7G5135



ART.	LOCH FORO HOLE	KG
75140	Ø10,5 mm 0,24	

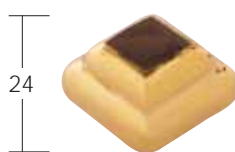

ART.	LOCH FORO HOLE	KG
75145	Ø14,4 mm 0,08	

35x35



ART.	LOCH FORO HOLE	KG
75150	Ø14,4	
75151	Ø12,2	

vergoldet
dorato
gilder
7G5151



ART.	LOCH FORO HOLE	GEWINDE FILETTO THREAD	KG
75155	Ø28 mm	M 10x1	0,10

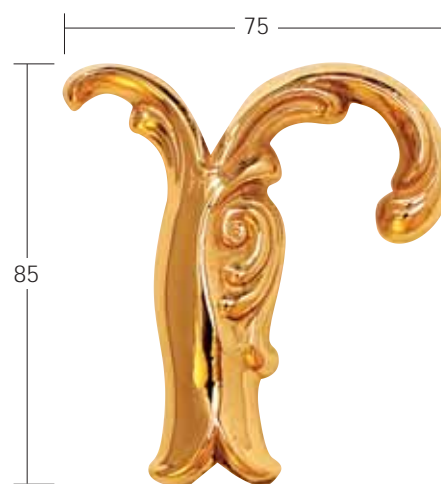

ART.	LOCH FORO HOLE	KG
75160	Ø12,2 mm 0,14	



Dekorative Hausnummern - Buchstaben
 lettere e numeri civici decorativi
 decorative house numbers and letters



ART.	GEWINDE FILETT THREAD
77010-0	M 6
" -"	"
" -"	"
" -"	"
77010-9	M 6



ART.	GEWINDE FILETT THREAD
77020-a	M 6
" -b	"
" -c	"
" -d	"
77020-e	M 6

kursiv-geschliffen, einbrennlackiert
 corsivi-rettificati e verniciati a forno
 italic-grinded, stove enamelled



ART.
77030-A
" -"
" -"
" -"
77030-Z



ART.
77035-a
" -"
" -"
" -"
77035-z



ART.
77040-0
" -"
" -"
" -"
77040-9



ART.
77041



ART.
77042



ART.
77043



ART.
77044

Florian

21 04 1986