



## 8.5 PALETTI FORGIATI

- 8.6 BARRE PUNZONATE
- 8.7 PUNTALI PER CANCELLI

## 8.5 HAND FORGED BALUSTERS

- 8.6 PUNCHED BARS
- 8.7 FINIALS FOR GATES

8.5



Pezzo iniziale caldo  
*Hot starting piece*



Esecuzione parte centrale  
*Middle part manufacturing*



Allungamento paletto  
*Baluster elongation*

Fase di rifinitura  
*Finishing phase*



## FORGIATO A MANO - HAND-FORGING

HAND GESCHMIEDET - FORJADO A MANO - FORGED A LA MAIN

Il pezzo riscaldato, assume la forma finale dopo aver subito una successione di deformazioni provocate dai magli o dalle presse mentre il pezzo è mosso liberamente a mano dall'operatore. Il risultato finale dipende quindi dall'abilità del forgiatore nel dosare la forza dei colpi in funzione della velocità di movimento e della temperatura del ferro.

The heated baluster gets the final shape after undergoing to a series of deformations made by the hammer or by the press machine.

During this process the piece is handled and freely moved by the operator using his hands.

So the final result depends from the ability of the forger in dosing his strength when hitting the piece, according with the movement speed and with the iron temperature.

Das geheizte Werkstück nimmt seine Endform an, nachdem es einer Verformungsfolge unterzogen wurde, die dadurch entstehen, daß der Fachhandwerker das Stück frei von Hand unter den Gesenkhammer oder der Presse fachgerecht verschiebt. Das Endergebnis ist von der Fähigkeit des Schmiedes die Kraft der Schlägen in Abhängigkeit von der Geschwindigkeit und der Temperatur des Eisens zu dosieren.

La pieza calentada toma su forma final después de sufrir una sucesión de deformaciones causadas por los martillos pilones o por las prensas mientras la pieza es movida liberamente a mano por el operador.

Por lo tanto el resultado final depende de la habilidad del forjador en el dosificar la fuerza de los golpes en función de la velocidad de movimiento y de la temperatura del hierro.

La pièce chauffée prend la forme finale après avoir subi une succession de déformations causées par les marteaux-pilons ou les presses. Pendant cette opération la pièce est mue librement par l'opérateur. Le résultat final dépend donc de l'habileté du forger qui doit doser la force des coups en fonction de la vitesse du mouvement et de la température du fer.

# PALETTI FORGIATI

## HAND FORGED BALUSTERS

8.5

Artifer®

The logo icon for Artifer, featuring a stylized figure of a person with arms raised, enclosed in a square frame.

*particolari che fanno la differenza • details which make the difference*



*particolari che fanno la differenza • details which make the difference*

8.5

 *Martellato*  
Hammered

 *Rifinito a caldo*  
Hot finished

 *Forigato a mano*  
Hand forged

*Particolare finitura*  
Finish detail

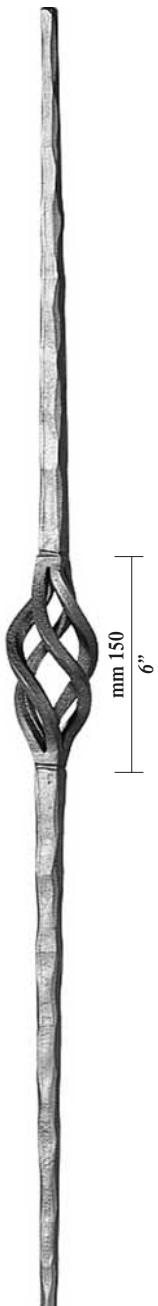

mm 70 x 1000 h  
2-3/4" x 39-3/8" h  
8501 



mm 35 x 1000 h  
1-3/8" x 39-3/8" h  
8503  ■ 14 9/16"



mm 25 x 1000 h  
1" x 39-3/8" h  
8505  ■ 12 1/2"

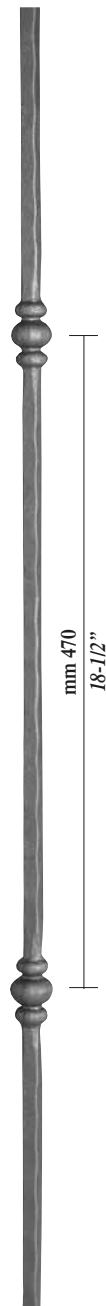

mm 25 x 1000 h  
1" x 39-3/8" h  
8507  ■ 12 1/2"

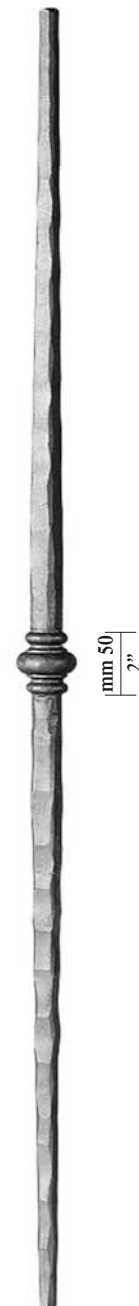

mm 50 x 1000 h  
2" x 39-3/8" h  
8510 



mm 16 x 1000 h  
5/8" x 39-3/8" h  
8515 

■ *Ferro pieno quadro*  
Square iron

■ *Ferro pieno piatto*  
Flat iron

● *Ferro pieno tondo*  
Round iron

8.5

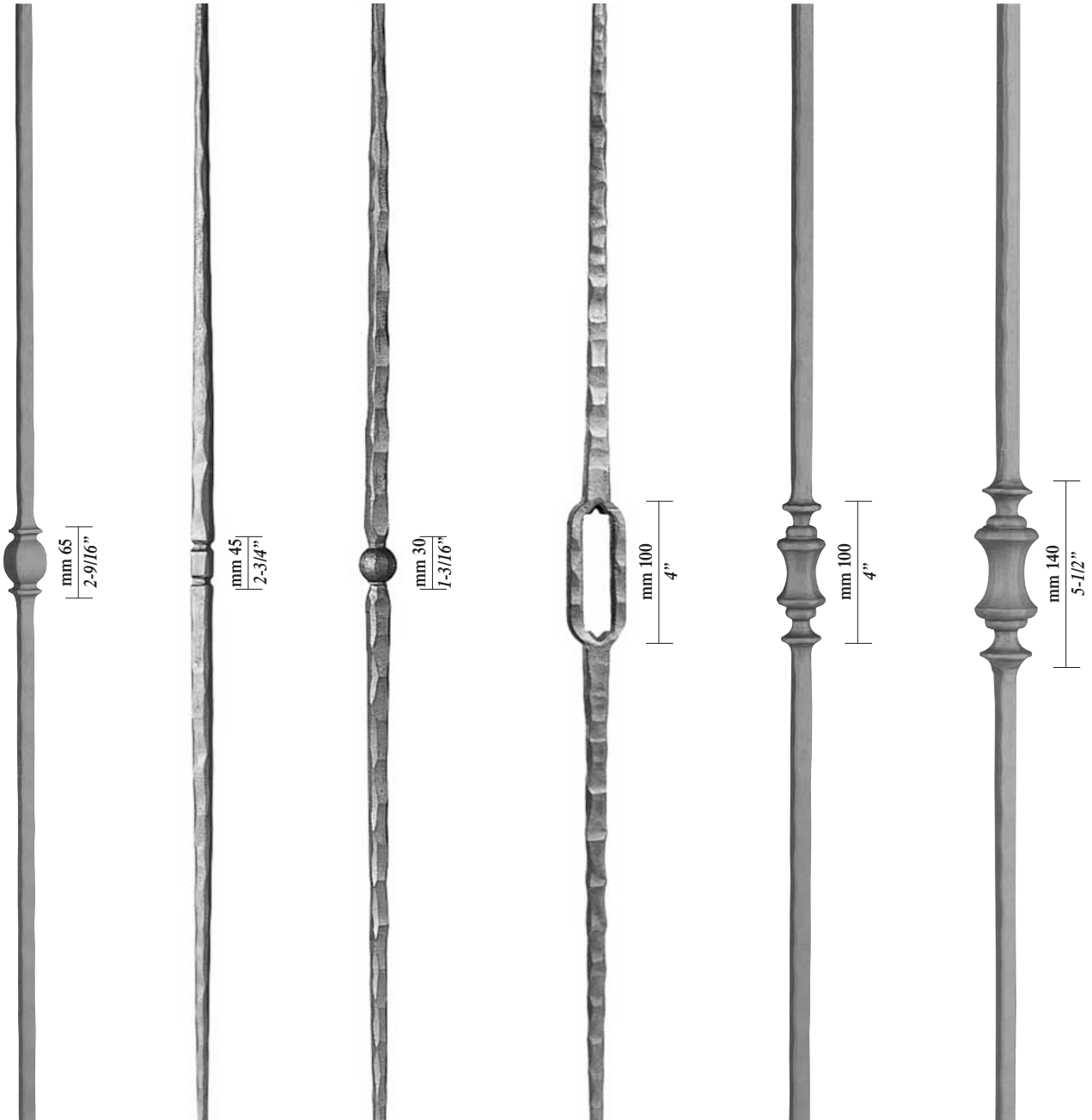

mm 30 x 1000 h  
1-3/16" x 39-3/8" h  
8517 ■ 14 9/16"

mm 16 x 1000 h  
5/8" x 39-3/8" h  
8520 ■

mm 25 x 1000 h  
1" x 39-3/8" h  
8525 ■

mm 60 x 1000 h  
2-3/8" x 39-3/8" h  
8530 ■

mm 30 x 1000 h  
1-3/16" x 39-3/8" h  
8534 ■ 12 1/2"

mm 45 x 1000 h  
1-3/4" x 39-3/8" h  
8535 ■ 14 9/16"

 *Martellato*  
Hammered

 *Rifinito a caldo*  
Hot finished

 *Forigato a mano*  
Hand forged

*Particolare finitura*  
Finish detail

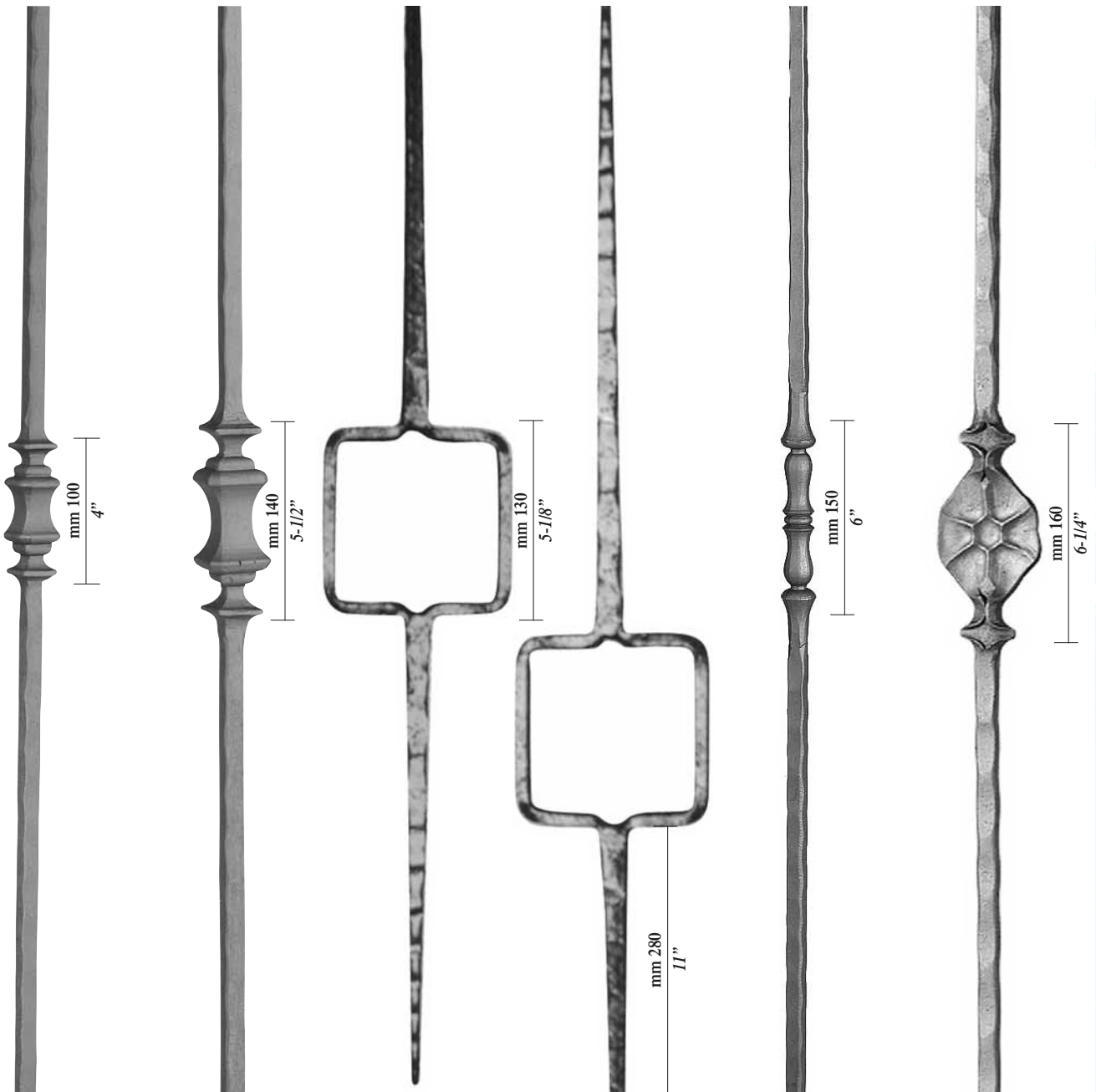



mm 35 x 1000 h  
1-3/8" x 39-3/8" h  
8538  ■ 12 1/2"

mm 45 x 1000 h  
1-3/4" x 39-3/8" h  
8539  ■ 14 9/16"

mm 140 x 1000 h  
5-1/2" x 39-3/8" h  
8545 

mm 140 x 1000 h  
5-1/2" x 39-3/8" h  
8550 

mm 25 x 1000 h  
1" x 39-3/8" h  
8552  ■ 14

mm 65 x 1000 h  
2-9/16" x 39-3/8" h  
8560  ■ 14 9/16"

■ *Ferro pieno quadro*  
Square iron

■ *Ferro pieno piatto*  
Flat iron

● *Ferro pieno tondo*  
Round iron

8.5

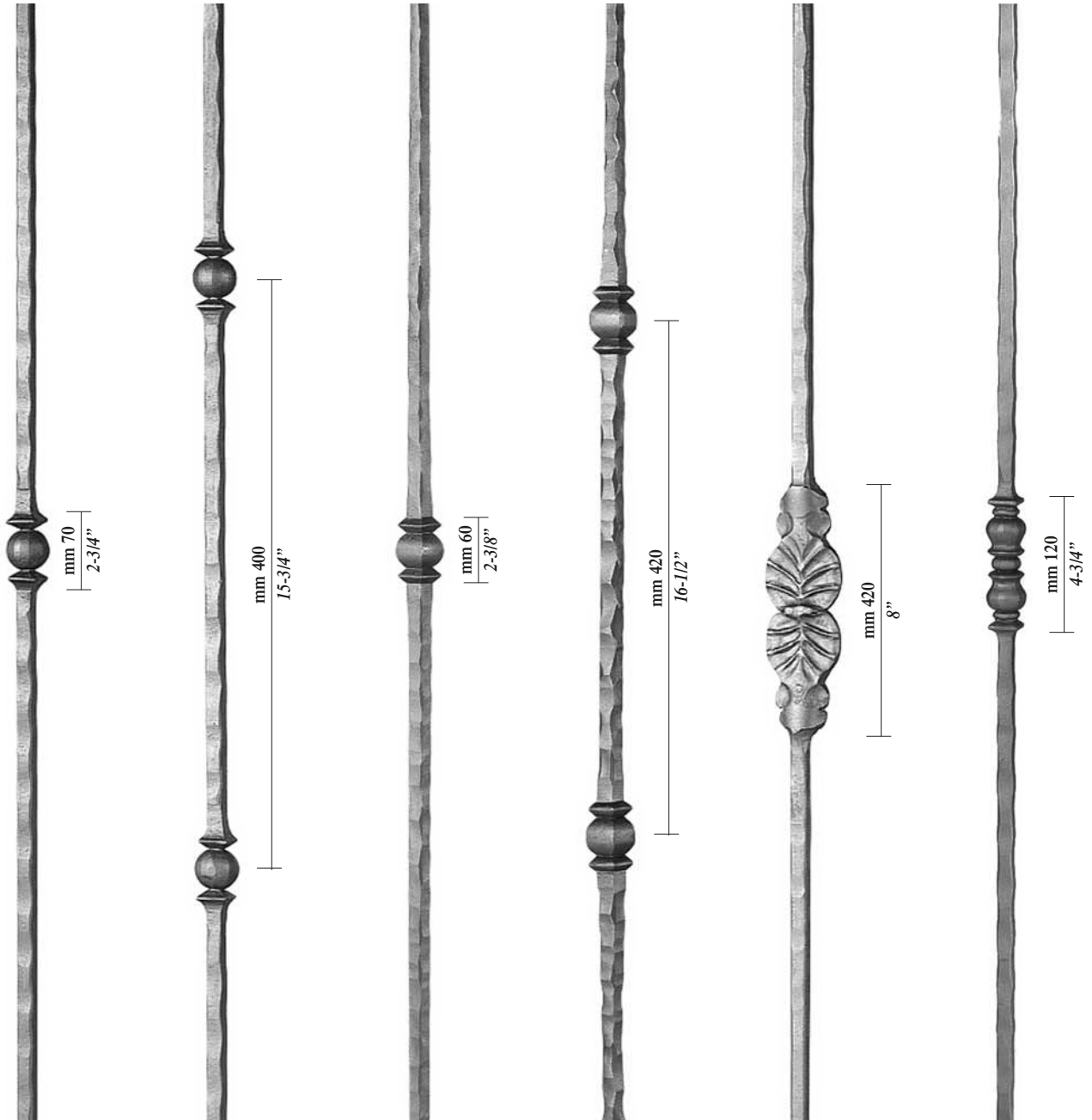

mm 35 x 1000 h  
1-3/8" x 39-3/8" h  
8557

mm 35 x 1000 h  
1-3/8" x 39-3/8" h  
8555

mm 35 x 1000 h  
1-3/8" x 39-3/8" h  
8563

mm 35 x 1000 h  
1-3/8" x 39-3/8" h  
8562

mm 60 x 1000 h  
2-3/8" x 39-3/8" h  
8565

mm 30 x 1000 h  
1-3/16" x 39-3/8" h  
8568





 *Martellato*  
Hammered

 *Rifinito a caldo*  
Hot finished

 *Fascettato*  
With collars

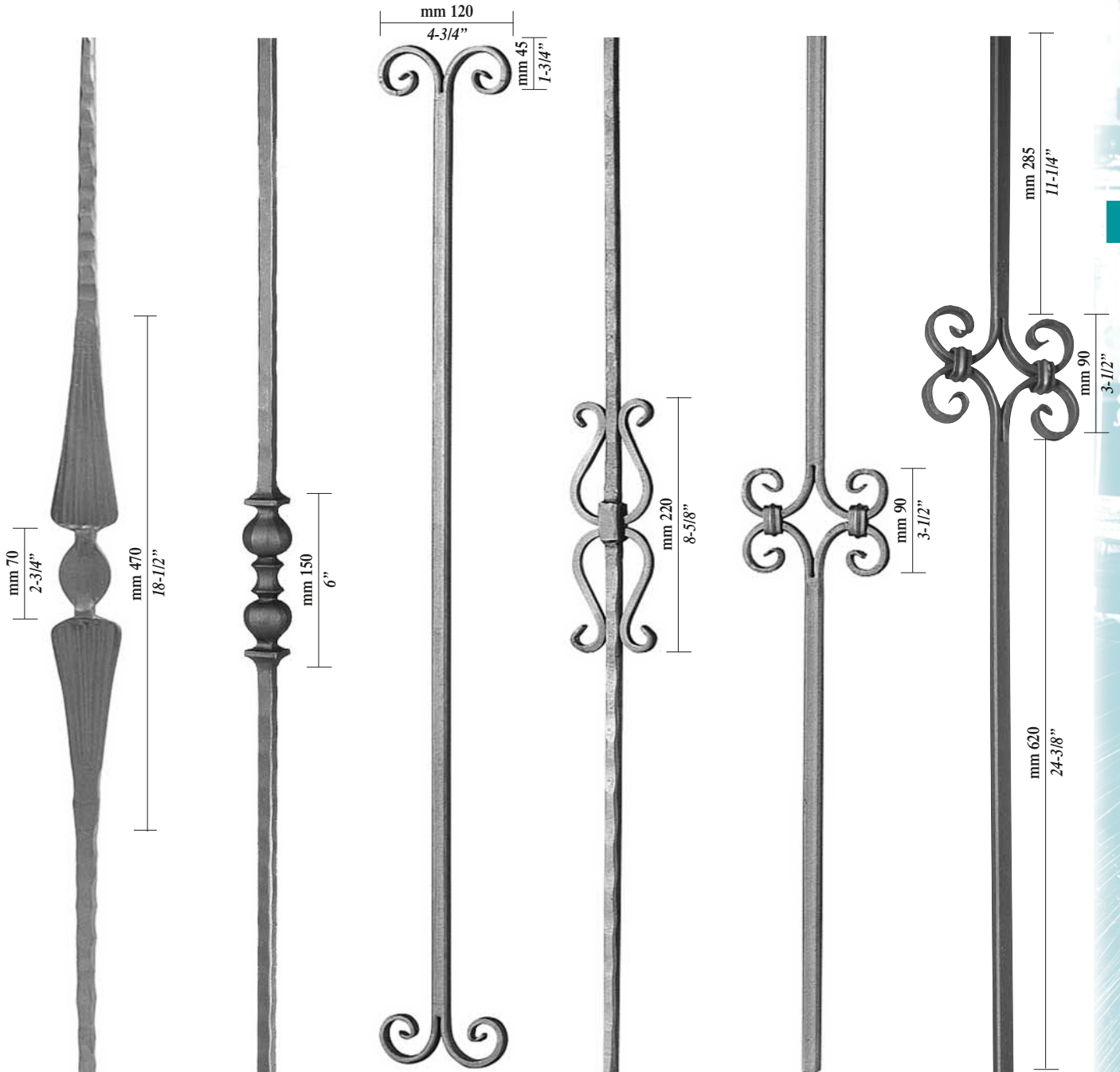
*Particolare finitura*  
Finish detail





mm 60 x 1000 h  
2-3/8" x 39-3/8" h  
8570  ■ 14 9/16"

mm 40 x 1000 h  
1-5/8" x 39-3/8" h  
8572  ■ 14 9/16"

mm 120 x 1000 h  
4-3/4" x 39-3/8" h  
8575  ■ 14 9/16"

mm 75 x 1000 h  
3" x 39-3/8" h  
8580  ■ 12 1/2"

mm 120 x 1000 h  
4-3/4" x 39-3/8" h  
8585  ■ 14 9/16"

mm 120 x 1000 h  
4-3/4" x 39-3/8" h  
8590  ■ 14 9/16"

■ *Ferro pieno quadro*  
Square iron

■ *Ferro pieno piatto*  
Flat iron

● *Ferro pieno tondo*  
Round iron

8.5



mm 1000 h  
39" x 39-3/8" h

8591 ■ 12 1/2"



mm 1000 h  
39" x 39-3/8" h

8592 ■ 14 9/16"

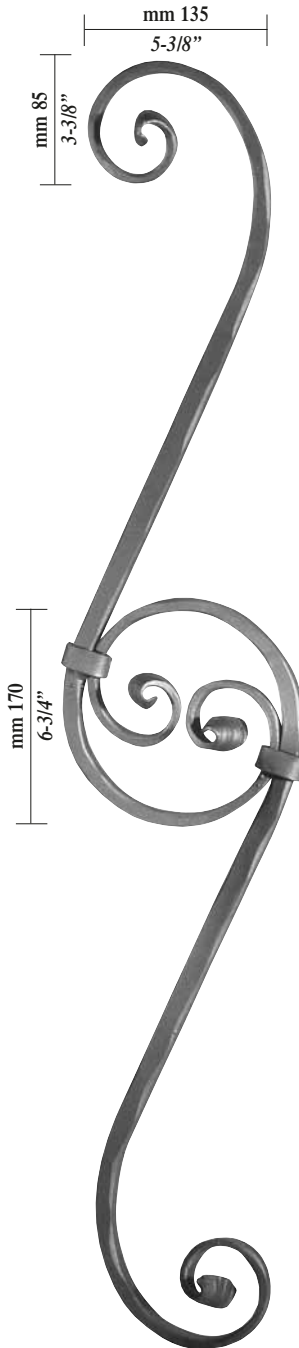

mm 155 x 1000 h  
6-1/8" x 39-3/8" h

8595



mm 140 x 1000 h  
5-1/2" x 39-3/8" h

8600

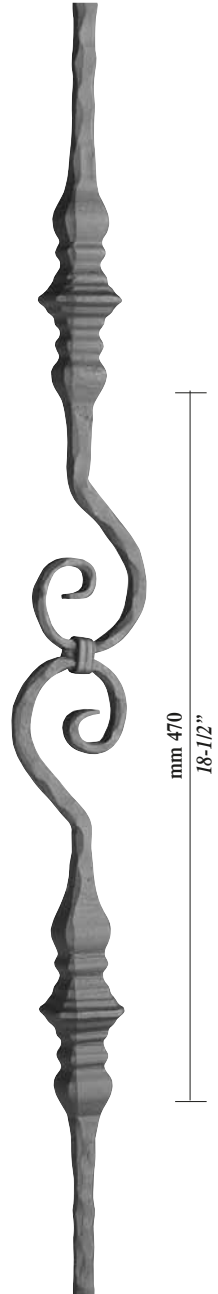

mm 80 x 1000 h  
3-1/8" x 39-3/8" h

8602 ■ 14 9/16"

 *Martellato*  
Hammered

 *Rifinito a caldo*  
Hot finished

 *Forigato a mano*  
Hand forged

*Particolare finitura*  
Finish detail

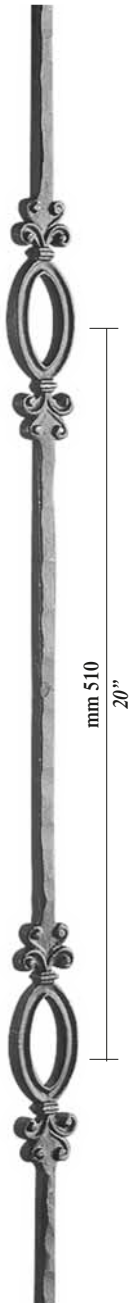

mm 52 x 1000 h  
2-1/16" x 39-3/8" h  
8605  ■ 14 9/16"

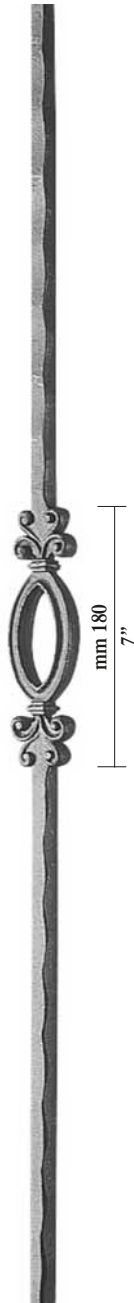

mm 52 x 1000 h  
2-1/16" x 39-3/8" h  
8610  ■ 14 9/16"

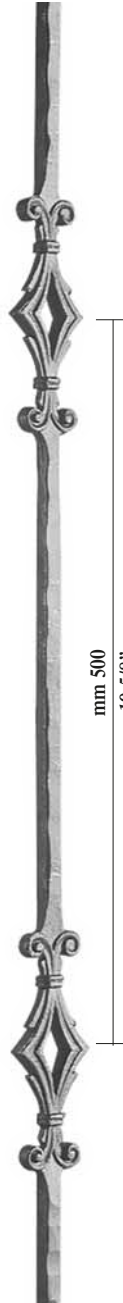

mm 60 x 1000 h  
2-3/8" x 39-3/8" h  
8615  ■ 14 9/16"



mm 60 x 1000 h  
2-3/8" x 39-3/8" h  
8620  ■ 14 9/16"



mm 25 x 1000 h  
1" x 39-3/8" h  
8625  ● 12 1/2"

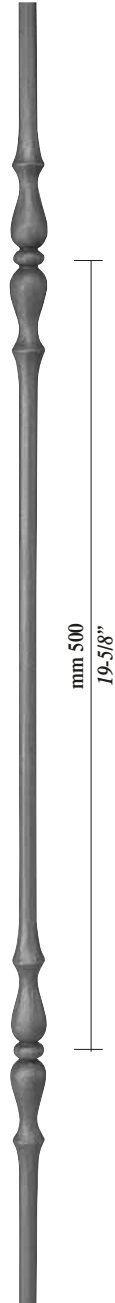

mm 25 x 1000 h  
1" x 39-3/8" h  
8627  ● 12 1/2"

■ *Ferro pieno quadro*  
Square iron

■ *Ferro pieno piatto*  
Flat iron

● *Ferro pieno tondo*  
Round iron

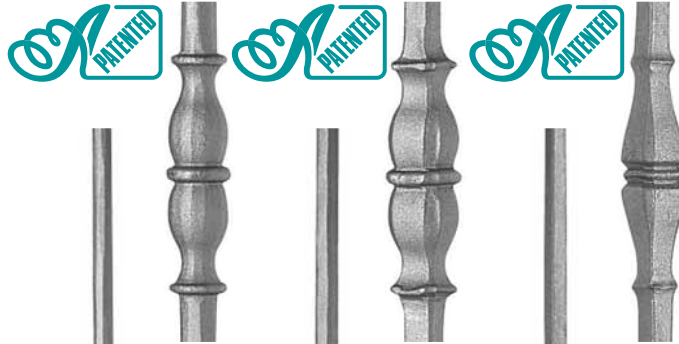

8.5



mm 25 x 1000 h  
1" x 39-3/8" h  
8626 ■ 12 1/2"



mm 25 x 1000 h  
1" x 39-3/8" h  
8628 ■ 12 1/2"

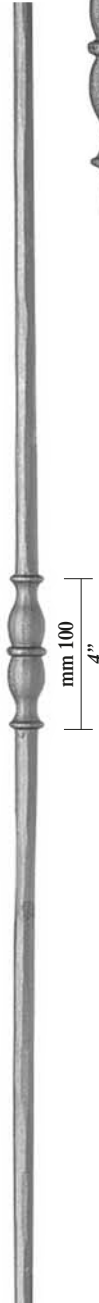

mm 25 x 1000 h  
1" x 39-3/8" h  
8630 ● 12 1/2"

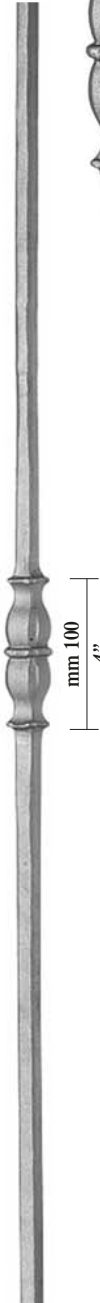

mm 25 x 1000 h  
1" x 39-3/8" h  
8632 ■ 12 1/2"

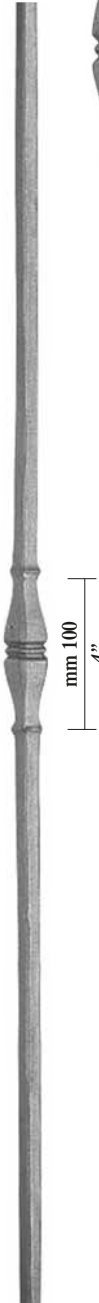

mm 25 x 1000 h  
1" x 39-3/8" h  
8635 ■ 12 1/2"

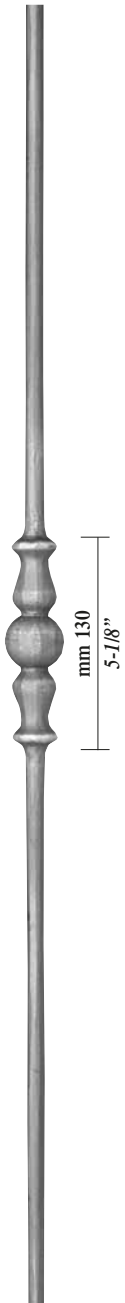

mm 40 x 1000 h  
1-5/8" x 39-3/8" h  
8643 ● 12 1/2"

 *Martellato*  
Hammered

 *Rifinito a caldo*  
Hot finished

 *Forgiato a mano*  
Hand forged

*Particolare finitura*  
Finish detail



mm 22 x 1000 h  
7/8" x 39-3/8" h  
8638  ● 12 1/2"

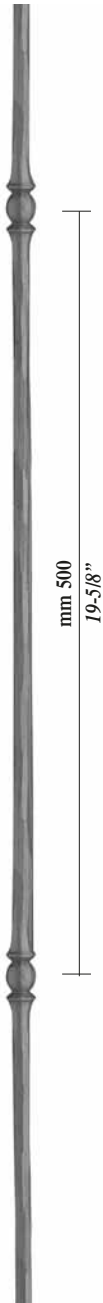

mm 22 x 1000 h  
7/8" x 39-3/8" h  
8639  ● 12

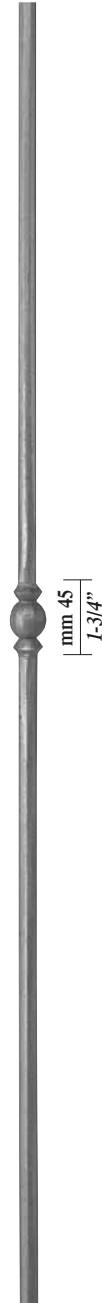

mm 25 x 1000 h  
1" x 39-3/8" h  
8640  ● 12

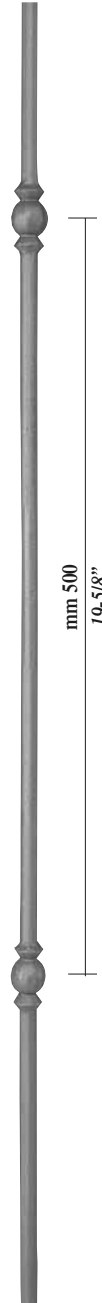

mm 25 x 1000 h  
1" x 39-3/8" h  
8642  ● 12

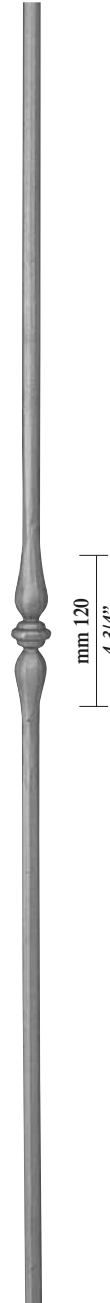

mm 25 x 1000 h  
1" x 39-3/8" h  
8645  ● 12

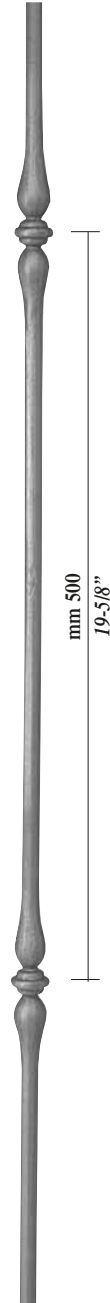

mm 25 x 1000 h  
1" x 39-3/8" h  
8648  ● 12 1/2"

■ *Ferro pieno quadro*  
Square iron

■ *Ferro pieno piatto*  
Flat iron

● *Ferro pieno tondo*  
Round iron

8.5

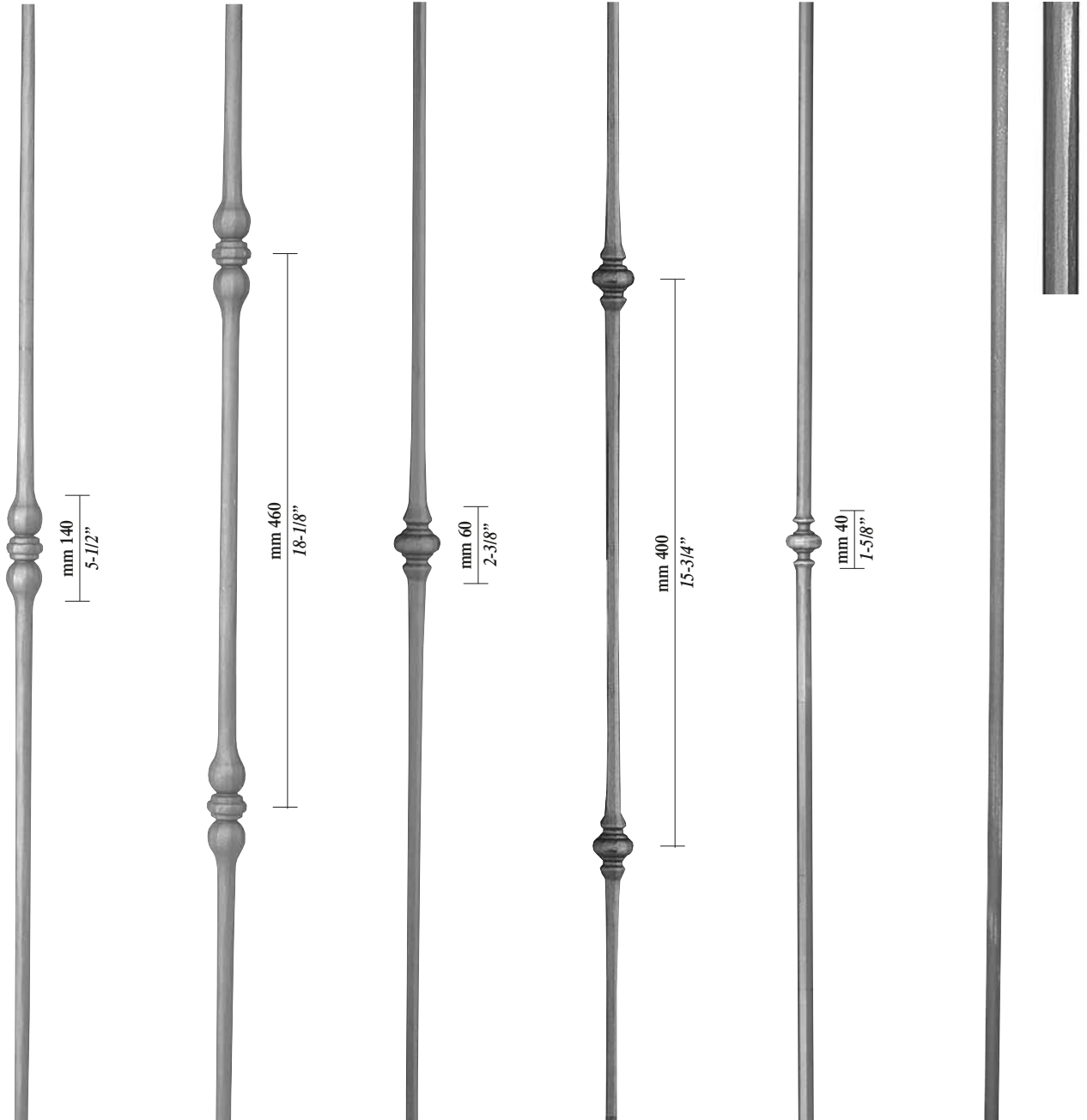

mm 30 x 1000 h  
1-3/16" x 39-3/8" h  
8646 ● 14 9/16"

mm 30 x 1000 h  
1-3/16" x 39-3/8" h  
8649 ● 14 9/16"

mm 40 x 1000 h  
1-5/8" x 39-3/8" h  
8650

mm 40 x 1000 h  
1-5/8" x 39-3/8" h  
8651

mm 25 x 1000 h  
1" x 39-3/8" h  
8652 ● 12 1/2"

mm 1000 h  
39-3/8" h  
8691 ● 12 1/2"

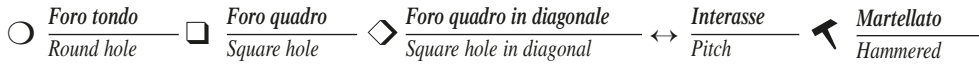

mm 2000 h 78-3/4" h  
N. ◻ 15

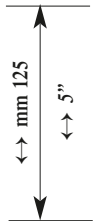
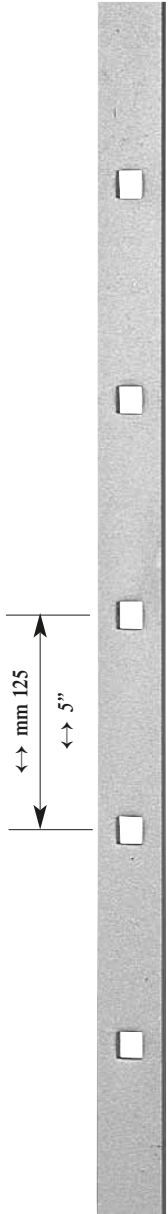

mm 2000 h 78-3/4" h  
N. ◻ 15

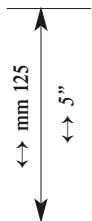

mm 2000 h 78-3/4" h  
N. ◻ 29



mm 2000 h 78-3/4" h  
N. ◻ 29

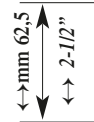

■ 30 x 8 1-3/16"x 5/16" h

8800 ◻ 12 1/2"  
8801 ◻ 14 9/16"

■ 35 x 6 1-3/8"x 1/4" h

8802 ◻ 12 1/2"  
8803 ◻ 14 9/16"

■ 40 x 8 1-3/16"x 5/16" h

8804 ◻ 12 1/2"  
8805 ◻ 14 9/16"

◀ ■ 30 x 8 1-3/16"x 5/16" h

8800-082B ◻ 12 1/2"  
8801-082B ◻ 14 9/16"

◀ ■ 35 x 6 1-3/8"x 1/4" h

8800-084B ◻ 12 1/2"  
8801-084B ◻ 14 9/16"

◀ ■ 40 x 8 1-3/16"x 5/16" h

8800-087B ◻ 12 1/2"  
8801-087B ◻ 14 9/16"

■ 30 x 8 1-3/16"x 5/16" h

8806-082 ◻ 12 1/2"  
8807-082 ◻ 14 9/16"

■ 35 x 6 1-3/8"x 1/4" h

8806-084 ◻ 12 1/2"  
8807-084 ◻ 14 9/16"

■ 40 x 8 1-3/16"x 5/16" h

8806-087 ◻ 12 1/2"  
8807-087 ◻ 14 9/16"

◀ ■ 30 x 8 1-3/16"x 5/16" h

8806-082B ◻ 12 1/2"  
8807-082B ◻ 14 9/16"

◀ ■ 35 x 6 1-3/8"x 1/4" h

8806-084B ◻ 12 1/2"  
8807-084B ◻ 14 9/16"

◀ ■ 40 x 8 1-3/16"x 5/16" h

8806-087B ◻ 12 1/2"  
8807-087B ◻ 14 9/16"

■ Ferro pieno quadro  
Square iron

■ Ferro pieno piatto  
Flat iron

● Ferro pieno tondo  
Round iron

mm 2000 h 78-3/4" h  
N. ◇ 15

mm 2000 h 78-3/4" h  
N. ◇ 15

mm 2000 h 78-3/4" h  
N. ◇ 29

mm 2000 h 78-3/4" h  
N. ◇ 29

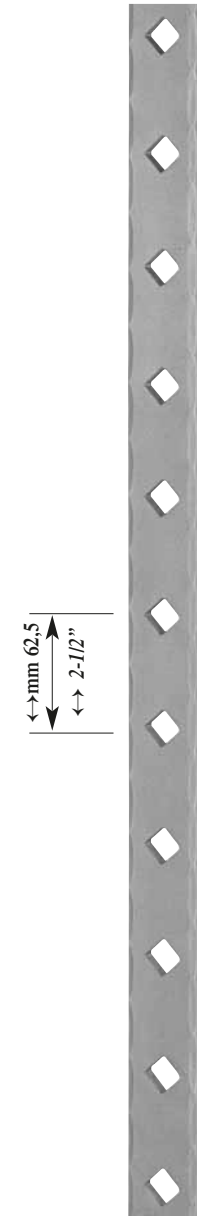
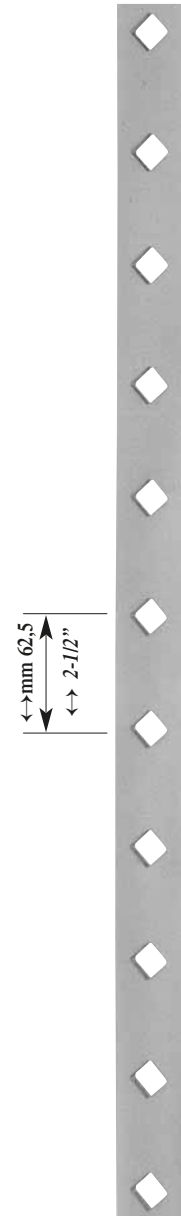
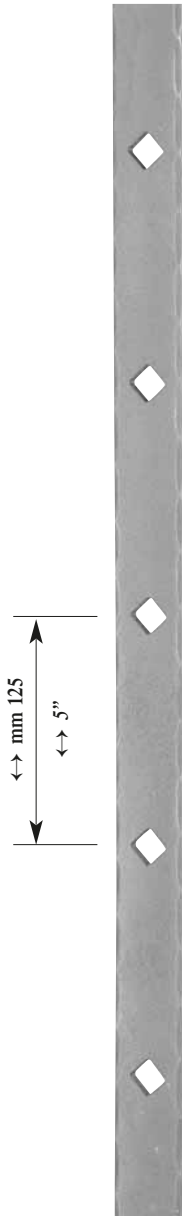
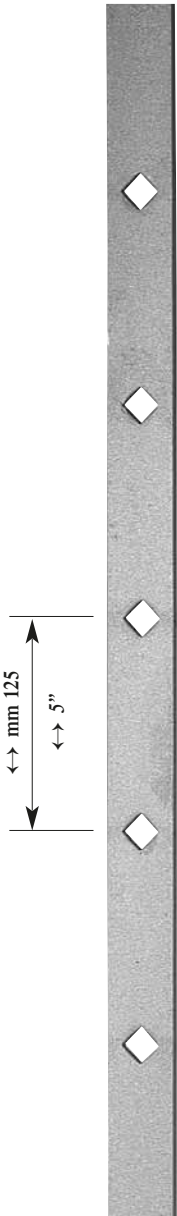

■ 30 x 8 1-3/16" x 5/16" h

8810 ◇ 12 1/2"

8811 ◇ 14 9/16"

■ 35 x 6 1-3/8" x 1/4" h

8812 ◇ 12 1/2"

8813 ◇ 14 9/16"

■ 40 x 8 1-3/16" x 5/16" h

8814 ◇ 12 1/2"

8815 ◇ 14 9/16"

◀ ■ 30 x 8 1-3/16" x 5/16" h

8810-082B ◇ 12 1/2"

8811-082B ◇ 14 9/16"

◀ ■ 35 x 6 1-3/8" x 1/4" h

8810-084B ◇ 12 1/2"

8811-084B ◇ 14 9/16"

◀ ■ 40 x 8 1-3/16" x 5/16" h

8810-087B ◇ 12 1/2"

8811-087B ◇ 14 9/16"

■ 30 x 8 1-3/16" x 5/16" h

8816-082 ◇ 12 1/2"

8817-082 ◇ 14 9/16"

■ 35 x 6 1-3/8" x 1/4" h

8816-084 ◇ 12 1/2"

8817-084 ◇ 14 9/16"

■ 40 x 8 1-3/16" x 5/16" h

8816-087 ◇ 12 1/2"

8817-087 ◇ 14 9/16"

◀ ■ 30 x 8 1-3/16" x 5/16" h

8816-082B ◇ 12 1/2"

8817-082B ◇ 14 9/16"

◀ ■ 35 x 6 1-3/8" x 1/4" h

8816-084B ◇ 12 1/2"

8817-084B ◇ 14 9/16"

◀ ■ 40 x 8 1-3/16" x 5/16" h

8816-087B ◇ 12 1/2"

8817-087B ◇ 14 9/16"



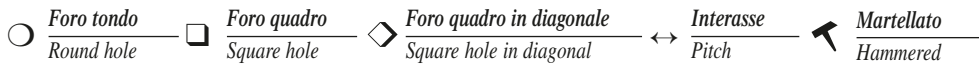

mm 2000 h 78-3/4" h  
N. ○ 15

mm 2000 h 78-3/4" h  
N. ○ 15

mm 2000 h 78-3/4" h  
N. ○ 29

mm 2000 h 78-3/4" h  
N. ○ 29

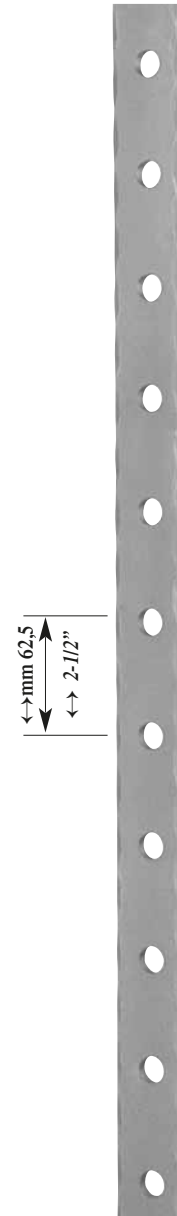
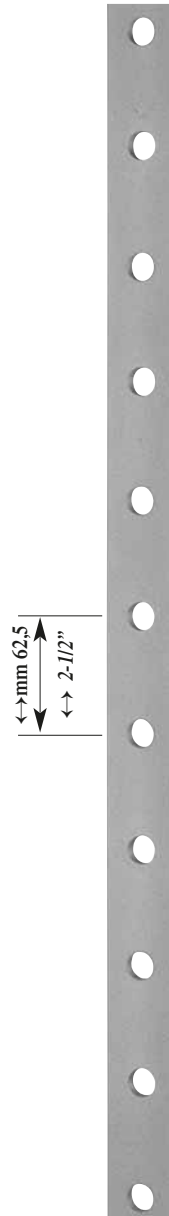
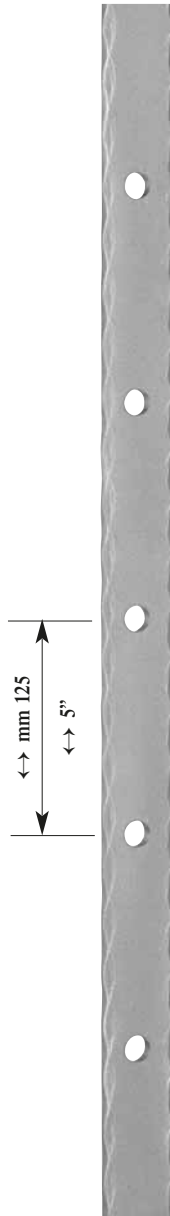
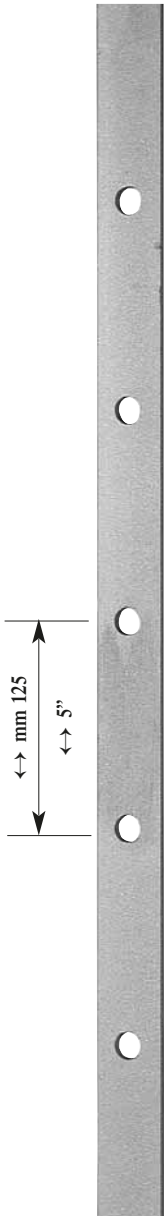

■ 30 x 8 1-3/16" x 5/16" h

8821-082 ○ 12 1/2"  
8820 ○ 14 9/16"

■ 35 x 6 1-3/8" x 1/4" h

8821-084 ○ 12 1/2"  
8821 ○ 14 9/16"

■ 40 x 8 1-3/16" x 5/16" h

8821-087 ○ 12 1/2"  
8822 ○ 14 9/16"

⤴ ■ 30 x 8 1-3/16" x 5/16" h

8820-082B ○ 12 1/2"  
8821-082B ○ 14 9/16"

⤴ ■ 35 x 6 1-3/8" x 1/4" h

8820-084B ○ 12 1/2"  
8821-084B ○ 14 9/16"

⤴ ■ 40 x 8 1-3/16" x 5/16" h

8820-087B ○ 12 1/2"  
8821-087B ○ 14 9/16"

■ 30 x 8 1-3/16" x 5/16" h

8823-082 ○ 12 1/2"  
8824-082 ○ 14 9/16"

■ 35 x 6 1-3/8" x 1/4" h

8823-084 ○ 12 1/2"  
8824-084 ○ 14 9/16"

■ 40 x 8 1-3/16" x 5/16" h

8823-087 ○ 12 1/2"  
8824-087 ○ 14 9/16"

⤴ ■ 30 x 8 1-3/16" x 5/16" h

8823-082B ○ 12 1/2"  
8824-082B ○ 14 9/16"

⤴ ■ 35 x 6 1-3/8" x 1/4" h

8823-084B ○ 12 1/2"  
8824-084B ○ 14 9/16"

⤴ ■ 40 x 8 1-3/16" x 5/16" h

8823-087B ○ 12 1/2"  
8824-087B ○ 14 9/16"

■ *Ferro pieno quadro*  
Square iron

■ *Ferro pieno piatto*  
Flat iron

● *Ferro pieno tondo*  
Round iron

mm 2000 h 78-3/4" h



↔ mm 125  
↔ 5"

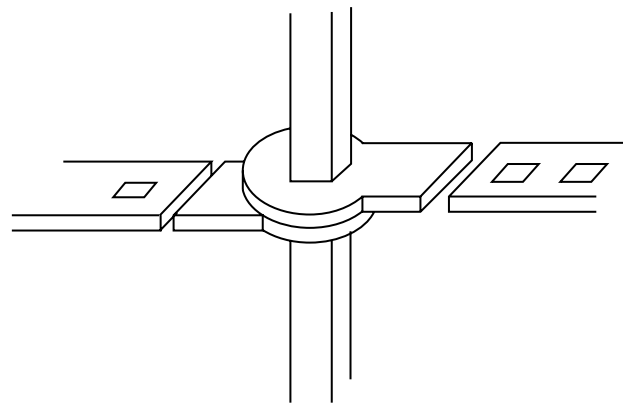
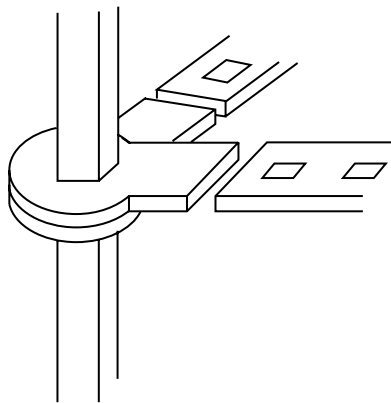

■ 30 x 6 1-3/16" x 1/4" h

8850 ■ 30 x 6 1-3/6" x 1-1/4"

8851 ◀ ■ 30 x 6 1-3/6" x 1-1/4"

mm 70 x 110 h 1-3/16" x 1/4" h

8825 □ 32 1-1/4"

mm 70 x 110 h 2-3/4" x 4-3/8" h

8830 □ 32 1-1/4"



 *Martellato*  
Hammered

 *Rifinito a caldo*  
Hot finished



 *Forigato a mano*  
Hand forged

*Particolare finitura*  
Finish detail





	mm 300 h	12" h
8900	 ■ 25	1"
8901	 ■ 30	1-3/16"
8902	 ■ 40	1-5/8"





	mm 350 h	13-3/4" h
8905	 ■ 25	1"
8906	 ■ 30	1-3/16"
8907	 ■ 40	1-5/8"



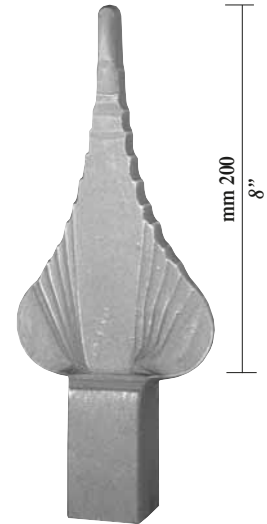

	mm 350 h	13-3/4" h
8910	 ■ 25	1"
8911	 ■ 30	1-3/16"
8912	 ■ 40	1-5/8"



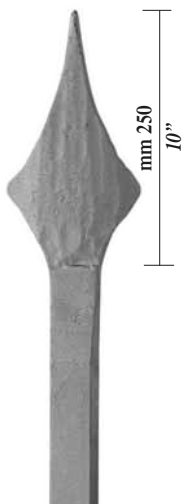

	mm 110 x 270 h	4-3/8" x 10-5/8" h
8913-031	 ■ 25	1"
8913-032	 ■ 30	1-3/16"
8913-034	 ■ 40	1-5/8"



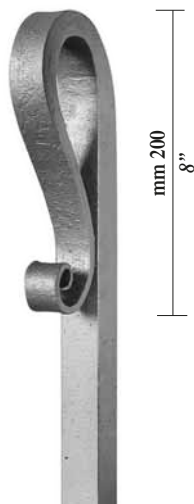

	mm 350 h	13-3/4" h
8915	 ■ 25	1"
8916	 ■ 30	1-3/16"
8917	 ■ 40	1-5/8"





	mm 350 h	13-3/4" h
8920	 ■ 25	1"
8921	 ■ 30	1-3/16"
8922	 ■ 40	1-5/8"



	mm 300 h	12" h
8925	 ■ 25	1"
8926	 ■ 30	1-3/16"
8927	 ■ 40	1-5/8"



	mm 300 h	12" h
8930	 ■ 20	3/4"
8931	 ■ 25	1"

■ **Ferro pieno quadro**  
Square iron

■ **Ferro pieno piatto**  
Flat iron

● **Ferro pieno tondo**  
Round iron

8.7

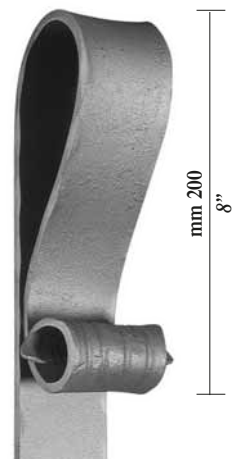
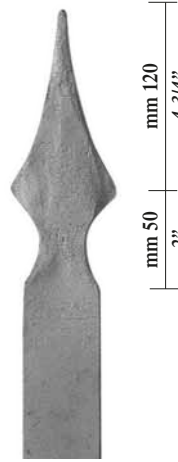
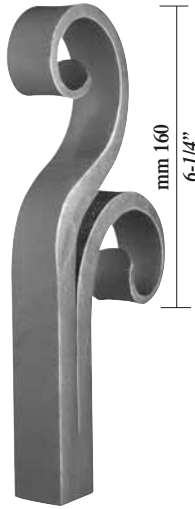
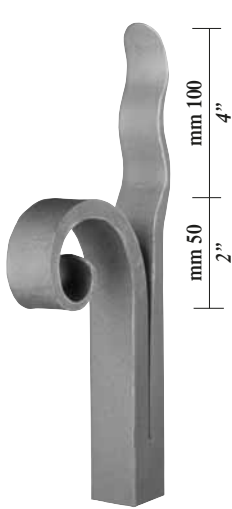

mm 110 x 270 h 4-3/8" x 10-5/8" h	
8932-032	■ 30 1-3/16"
8932-034	■ 40 1-5/8"

mm 110 x 250 h 4-3/8" x 10" h	
8933-032	■ 30 1-3/16"
8933-034	■ 40 1-5/8"

mm 300 h 12" h	
8935	☞ ■ 60 x 6 2-3/8" x 1/4"
8936	☜ ☞ ■ 60 x 6 2-3/8" x 1/4"

mm 300 h 12" h	
8940	☞ ■ 60 x 6 2-3/8" x 1/4"
8941	☜ ☞ ■ 60 x 6 2-3/8" x 1/4"

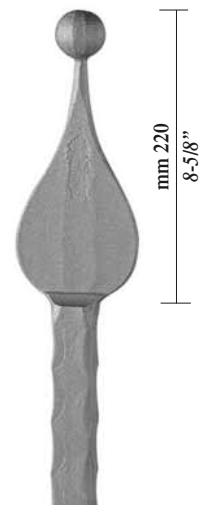
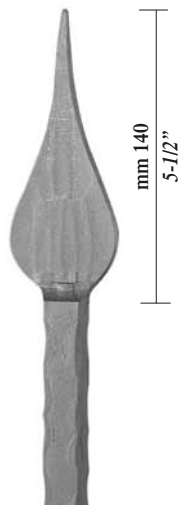
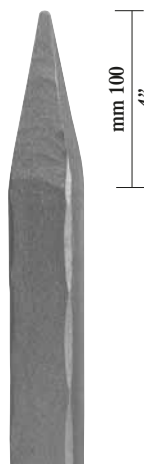
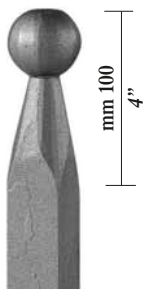

mm 150 h 6" h	
8945	■ 25 1"
8946	☜ ■ 25 1"
8947	■ 30 1-3/16"
8948	☜ ■ 30 1-3/16"
8949	■ 40 1-5/8"
8950	☜ ■ 40 1-5/8"

mm 300 h 12" h	
8951	☜ ■ 25 1"
8952	☜ ■ 30 1-3/16"

mm 350 h 13-3/4" h	
8955	☜ ■ 25 1"
8956	☜ ■ 30 1-3/16"
8957	☜ ■ 40 1-5/8"

mm 350 h 13-3/4" h	
8960	☜ ■ 25 1"
8961	☜ ■ 30 1-3/16"
8962	☜ ■ 40 1-5/8"







 *Martellato*  
Hammered

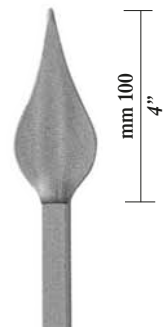
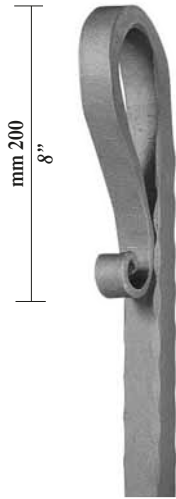





 *Rifinito a caldo*  
Hot finished







 *Forigato a mano*  
Hand forged

*Particolare finitura*  
Finish detail







	mm 350 h	13-3/4" h
8965	  ■ 25	1"
8966	  ■ 30	1-3/16"
8967	  ■ 40	1-5/8"

	mm 350 h	13-3/4" h
8970	  ■ 25	1"
8971	  ■ 30	1-3/16"
8972	  ■ 40	1-5/8"

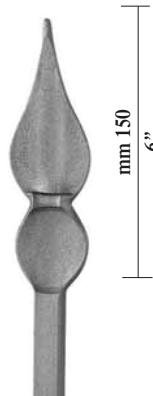
	mm 350 h	13-3/4" h
8975	  ■ 25	1"
8976	  ■ 30	1-3/16"
8977	  ■ 40	1-5/8"



	mm 150 h	6" h
9250	■ 12	1/2"
9251	■ 14	9/16"
9250-027	■ 16	5/8"



	mm 150 h	6" h
9250-025B	 ■ 12	1/2"
9250-026B	 ■ 14	9/16"
9250-027B	 ■ 16	5/8"

	mm 150 h	6" h
9250-045	● 12	1/2"
9253	● 14	9/16"
9250-047	● 16	5/8"

	mm 200 h	8" h
9255	■ 12	1/2"
9256	■ 14	9/16"
9255-027	■ 16	5/8"

	mm 200 h	8" h
9255-025B	 ■ 12	1/2"
9255-026B	 ■ 14	9/16"
9255-027B	 ■ 16	5/8"

■ Ferro pieno quadro  
Square iron

■ Ferro pieno piatto  
Flat iron

● Ferro pieno tondo  
Round iron

8.7

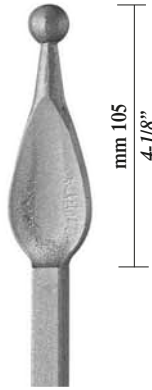

mm 200 h	8" h
9255-045 ● 12	1/2"
9255-046 ● 14	9/16"
9255-047 ● 16	5/8"

mm 200 h	8" h
9258-025 ■ 12	1/2"
9258 ■ 14	9/16"
9258-027 ■ 16	5/8"

mm 200 h	8" h
9258-025B ⚡ ■ 12	1/2"
9258-026B ⚡ ■ 14	9/16"
9258-027B ⚡ ■ 16	5/8"

mm 200 h	8" h
9258-045 ● 12	1/2"
9258-046 ● 14	9/16"
9258-047 ● 16	5/8"

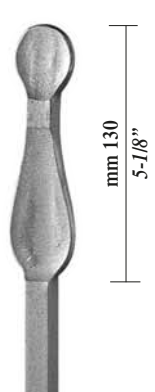
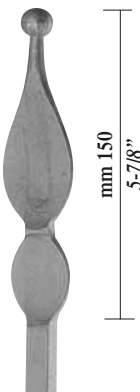

mm 200 h	7-7/8" h
9259-025 ■ 12	1/2"
9259-026 ■ 14	9/16"
9259-027 ■ 16	5/8"

mm 200 h	7-7/8" h
9259-025B ⚡ ■ 12	1/2"
9259-026B ⚡ ■ 14	9/16"
9259-027B ⚡ ■ 16	5/8"

mm 200 h	7-7/8" h
9259-045 ● 12	1/2"
9259-046 ● 14	9/16"
9259-047 ● 16	5/8"

mm 200 h	7-7/8" h
9260 ■ 12	1/2"
9261 ■ 14	9/16"
9260-027 ■ 16	5/8"



 *Martellato*  
Hammered



 *Rifinito a caldo*  
Hot finished

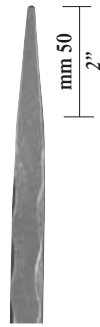
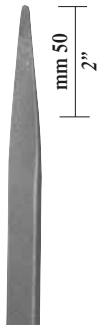

 *Forigato a mano*  
Hand forged

*Particolare finitura*  
Finish detail







	mm 150 h	6" h
9265	 ■ 12 1/2"	
9266	 ■ 14 9/16"	
9265-027	 ■ 16 5/8"	

	mm 150 h	6" h
9265-025B	 ■ 12 1/2"	
9265-026B	 ■ 14 9/16"	
9265-027B	 ■ 16 5/8"	

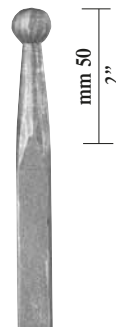

	mm 150 h	6" h
9265-045	 ● 12 1/2"	
9265-046	 ● 14 9/16"	
9265-047	 ● 16 5/8"	



	mm 150 h	6" h
9270	■ 12 1/2"	
9271	■ 14 9/16"	
9270-027	■ 16 5/8"	



	mm 150 h	6" h
9270-025B	 ■ 12 1/2"	
9270-026B	 ■ 14 9/16"	
9270-027B	 ■ 16 5/8"	

	mm 150 h	6" h
9270-045	● 12	
9270-046	● 14	
9270-047	● 16	

	mm 150 h	6" h
9272-025	 ■ 12 1/2"	
9272-026	 ■ 14 9/16"	
9272-027	 ■ 16 5/8"	

	mm 150 h	6" h
9272-025B	 ■ 12 1/2"	
9272-026B	 ■ 14 9/16"	
9272-027B	 ■ 16 5/8"	

■ Ferro pieno quadro  
Square iron

■ Ferro pieno piatto  
Flat iron

● Ferro pieno tondo  
Round iron

8.7



mm 150 h 6" h

9272-045	●	12	1/2"
9272-046	●	14	9/16"
9272-047	●	16	5/8"



mm 200 h 8" h

9273-025	■	12	1/2"
9273-026	■	14	9/16"
9273-027	■	16	5/8"



mm 200 h 8" h

9273-025B	▲	12	1/2"
9273-026B	▲	14	9/16"
9273-027B	▲	16	5/8"



mm 200 h 8" h

9273-045	●	12	1/2"
9273-046	●	14	9/16"
9273-047	●	16	5/8"

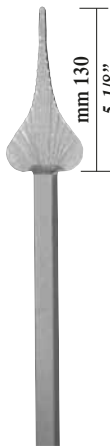

mm 250 h 10" h

9280-026	■	14	9/16"
9280-027	■	16	5/8"



mm 250 h 10" h

9280-046	●	14	9/16"
9280-047	●	16	5/8"

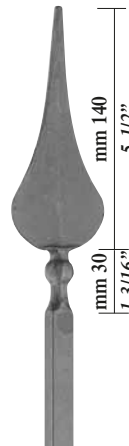

mm 250 h 10" h

9281-026	■	14	9/16"
9281-027	■	16	5/8"





mm 250 h 10" h

9281-026B	▲	14	9/16"
9281-027B	▲	16	5/8"



 *Martellato*  
Hammered

 *Rifinito a caldo*  
Hot finished

 *Forigato a mano*  
Hand forged

*Particolare finitura*  
Finish detail



mm 40 x 150 h 1-5/8"x 6" h  
9285-025 ■ 12 1/2"



mm 45 x 180 h 1-3/4"x 7" h  
9285-026 ■ 14 9/16"



mm 50 x 190 h 2"x 7-1/2" h  
9285-027 ■ 16 5/8"



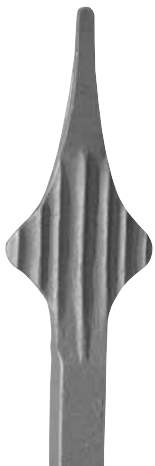

mm 55 x 200 h 1-3/16"x 8" h  
9285-028 ■ 18 11/16"





mm 62 x 210 h  
2-7/16"x 8-1/4" h  
9285-029 ■ 20 3/4"



150 h  
6" h  
9700  ■ 30 1-3/16"  
9701  ■ 40 1-5/8"



200 h  
8" h  
9705  ■ 30 1-3/16"  
9706  ■ 40 1-5/8"



*particolari che fanno la differenza • details which make the difference*

---

8.7