



## 8 PALETTI

- 8.1 PALETTI CON PALLINA FORGIATA E PALETTI CON SCHIACCIATURA
- 8.2 PALETTI CON LANCE A FIAMMA E PALETTI CON LANCE FORGIATE
- 8.3 PALETTI SPINATI
- 8.4 PALETTI IN OTTONE

## 8 BALUSTERS

- 8.1 BALUSTERS WITH HAND FORGED BALLS AND HOT STAMPED BALUSTERS
- 8.2 BALUSTERS WITH STAMPED FLAME SHAPE SPEARHEADS AND BALUSTERS WITH FORGED SPEARHEADS
- 8.3 "HERRING-BONE" BALUSTERS
- 8.4 BRASS BALUSTERS

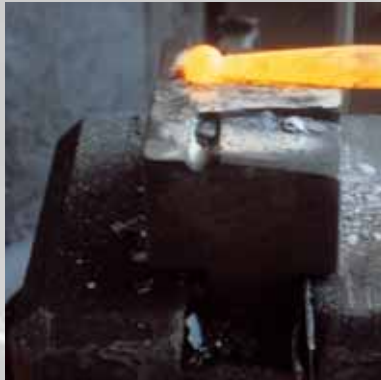

Esecuzione pallina  
*Ball manufacturing*

Esecuzione schiacciatura in automatico  
*Automatic crushing manufacturing*

Esecuzione lancia paletti serie 8110  
*Spearhead balusters manufacturing series 8110*

## **BATTUTO A CALDO - HOT HAMMERING** **SCHMIEDEN - FORJADO EN CALIENTE - FORGED A CHAUD**

Il pezzo viene riscaldato e poi pressato o battuto a mano con il martello o a macchina con il maglio.

The piece is heated and pressed or hand-hammered by means of a hammer or a power hammer machine.

Das Werkstück wird erhitzt und anschliessend gepresst oder von Hand mit einem Hammer oder Gesenkhammer geschmiedet.

La pieza es calentada y luego prensada o forjada a mano con el martillo o por medio de una máquina equipada con martillo pilón.

La pièce est chauffée puis pressée ou forgée à la main avec le marteau ou mécaniquement avec le marteau-pilon.

# PALETTI PER RECINZIONI

FENCING

BALUSTERS

8

Artifer®  

*particolari che fanno la differenza • details which make the difference*



*particolari che fanno la differenza • details which make the difference*

---

8.1

**PALETTI CON PALLINA FORGIATA**  
**BALUSTERS WITH HAND FORGED BALLS 8.1**

 **Martellato**  
Hammered

 **Rifinito a caldo**  
Hot finished

 **Forgiato a mano**  
Hand forged

**Particolare finitura**  
Finish detail

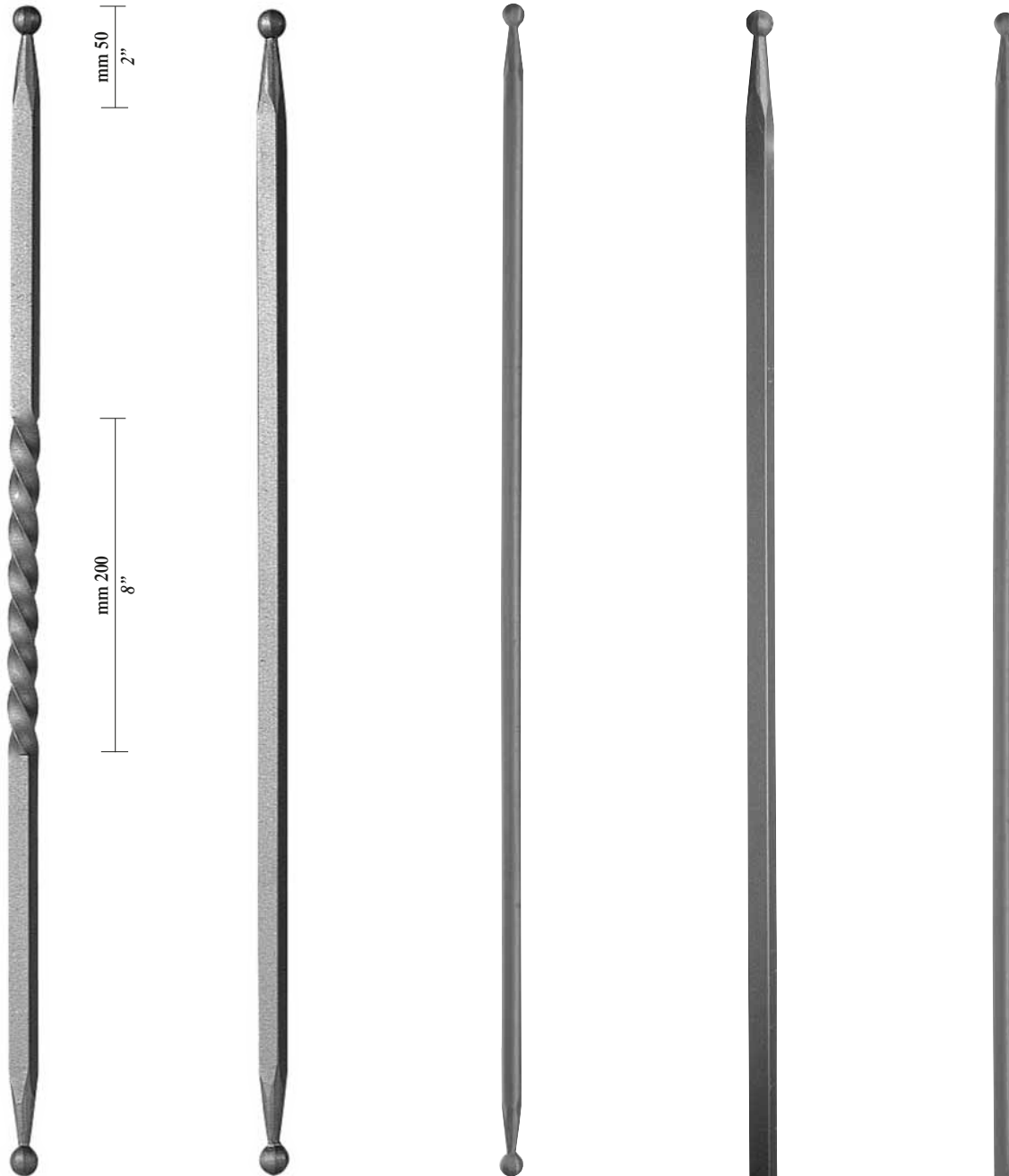

8.1

🌀 ■ 14 9/16"			🌀 ■ 14 9/16"			🌀 ● 14 9/16"			🌀 ■ 12 1/2"			🌀 ● 12 1/2"		
<b>8001</b>	700 h	27-1/2" h	<b>8003</b>	700 h	27-1/2" h	<b>8003-046</b>	700 h	27-1/2" h	<b>8005</b>	700 h	27-1/2" h	<b>8005-045</b>	700 h	27-1/2" h
<b>8002</b>	900 h	35-1/2" h	<b>8004</b>	900 h	35-1/2" h	<b>8003-146</b>	900 h	35-1/2" h	<b>8006</b>	900 h	35-1/2" h	<b>8005-145</b>	900 h	35-1/2" h
<b>8001-226</b>	1200 h	47-1/4" h	<b>8003-226</b>	1200 h	47-1/4" h	<b>8003-246</b>	1200 h	47-1/4" h	<b>8005-225</b>	1200 h	47-1/4" h	<b>8005-245</b>	1200 h	47-1/4" h
🌀 ■ 14 9/16"			🌀 ● 14 9/16"			🌀 ■ 12 1/2"			🌀 ● 12 1/2"					
<b>8007</b>	700 h	27-1/2" h	<b>8005-046</b>	700 h	27-1/2" h	<b>8007</b>	700 h	27-1/2" h	<b>8005-046</b>	700 h	27-1/2" h	<b>8007</b>	700 h	27-1/2" h
<b>8008</b>	900 h	35-1/2" h	<b>8005-146</b>	900 h	35-1/2" h	<b>8008</b>	900 h	35-1/2" h	<b>8005-146</b>	900 h	35-1/2" h	<b>8008</b>	900 h	35-1/2" h
<b>8005-226</b>	1200 h	47-1/4" h	<b>8005-246</b>	1200 h	47-1/4" h	<b>8005-226</b>	1200 h	47-1/4" h	<b>8005-246</b>	1200 h	47-1/4" h	<b>8005-226</b>	1200 h	47-1/4" h



■ *Ferro pieno quadro*  
Square iron

■ *Ferro pieno piatto*  
Flat iron

● *Ferro pieno tondo*  
Round iron

8.1

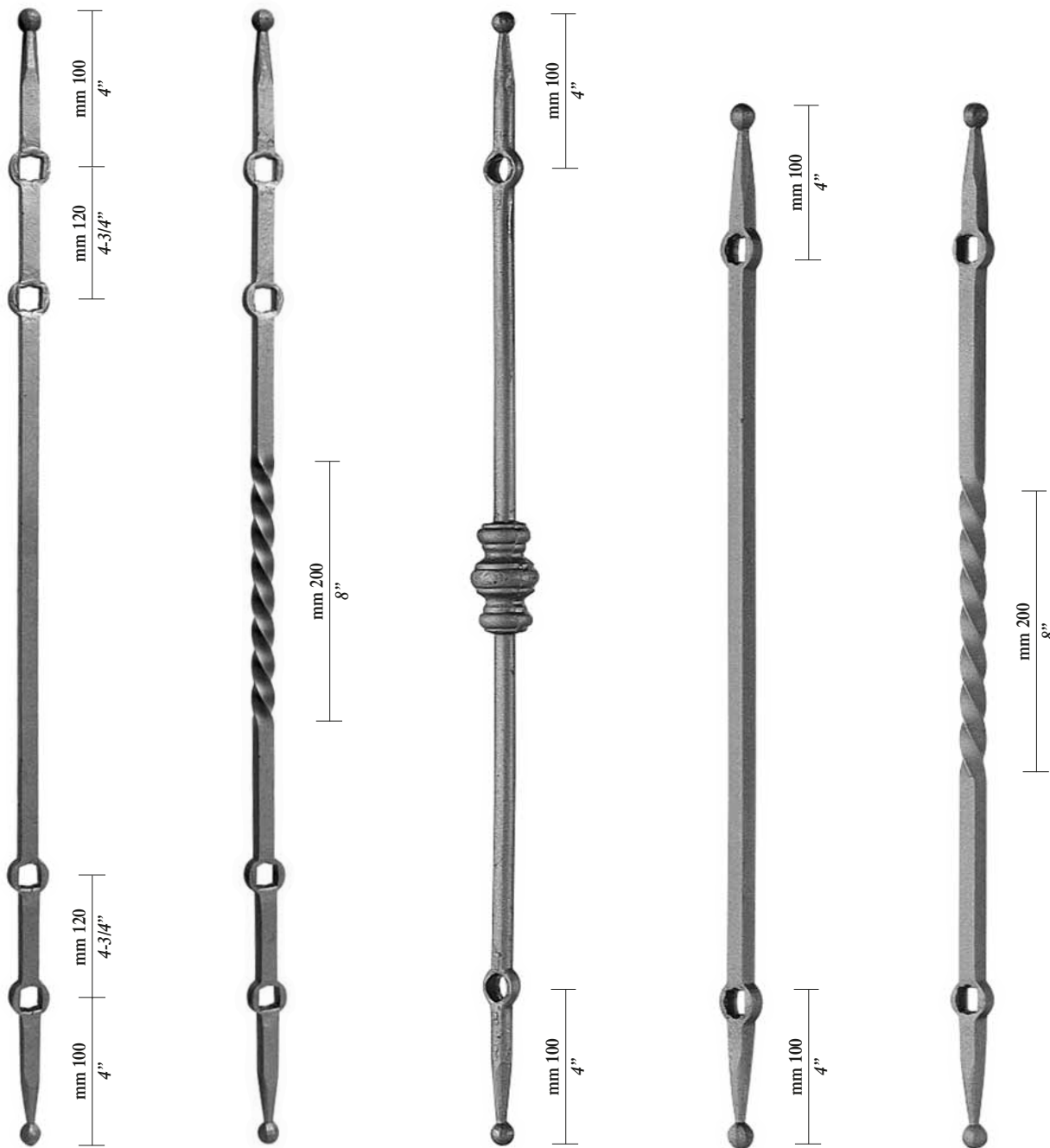

■ 14 9/16"

8010 900 h 35-1/2" h  
8010-226 1200 h 47-1/4" h

■ 14 9/16"

8012 900 h 35-1/2" h  
8012-226 1200 h 47-1/4" h

● 14 9/16"

8013 700 h 27-1/2" h  
8014 900 h 35-1/2" h  
8013-246 1200 h 47-1/4" h

■ 14 9/16"

8015 700 h 27-1/2" h  
8015-226 1200 h 47-1/4" h

■ 14 9/16"

8017 700 h 27-1/2" h





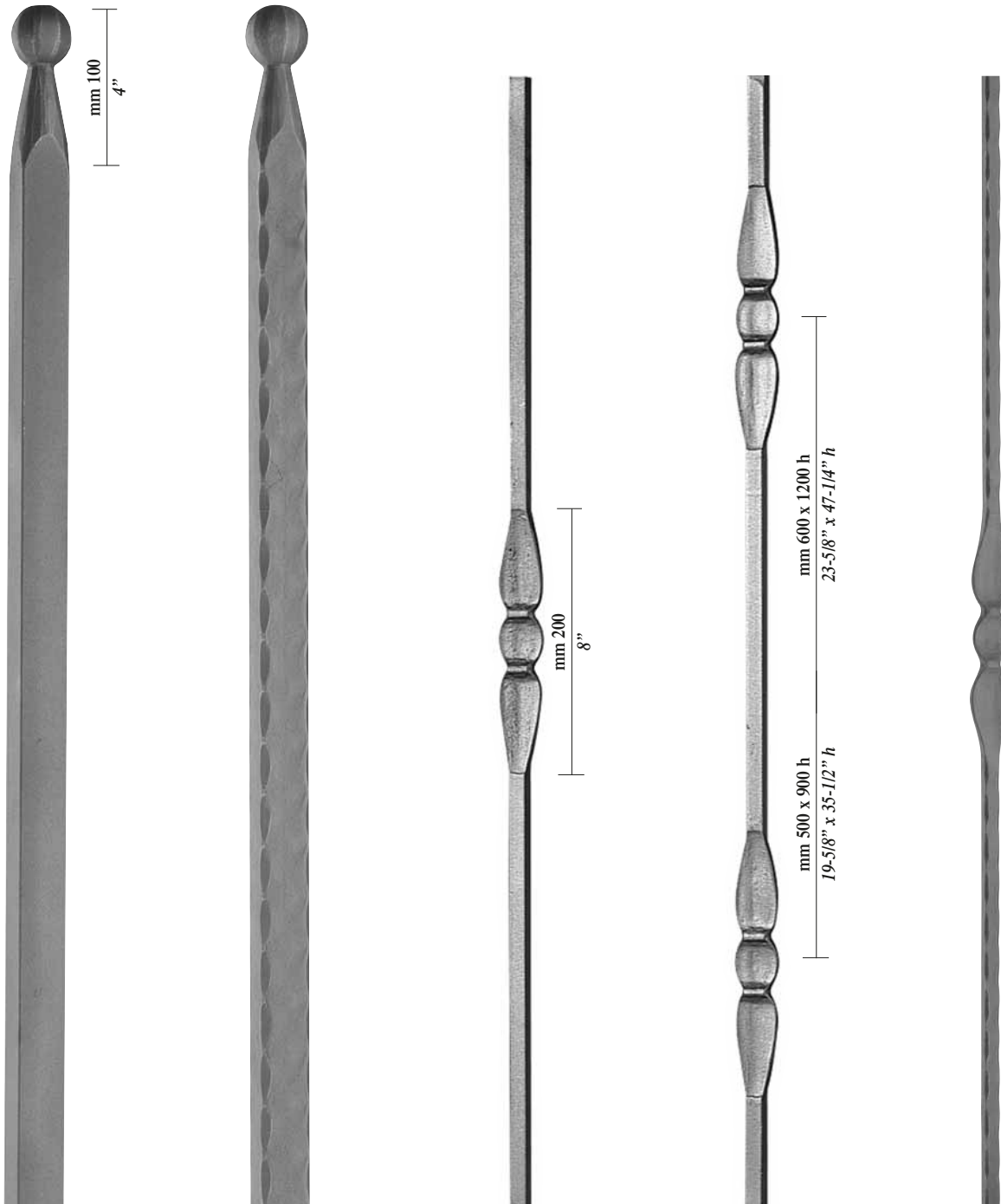

 *Martellato*  
Hammered

 *Rifinito a caldo*  
Hot finished

 *Forgiato a mano*  
Hand forged

*Particolare finitura*  
Finish detail



mm 1000 h	39-3/8" h	mm 1000 h	39-3/8" h	mm 900 h	35-1/2" h	mm 900 h	35-1/2" h	mm 900 h	35-1/2" h
8020	 ■ 25 1"	8020-031B	 ■ 25 1"	8026	■ 12 1/2"	8025	■ 12 1/2"	8026-025B	 ■ 12 1/2"
8023	 ■ 30 1-3/16"	8020-032B	 ■ 30 1-3/16"	8028	■ 14 9/16"	8027	■ 14 9/16"	8026-026B	 ■ 14 9/16"
								mm 1200 h 47-1/4" h	
								8026-225B	
								8026-226B	
								mm 1200 h 47-1/4" h	
								8025-225	
								8025-226	

■ *Ferro pieno quadro*  
Square iron

■ *Ferro pieno piatto*  
Flat iron

● *Ferro pieno tondo*  
Round iron

8.1

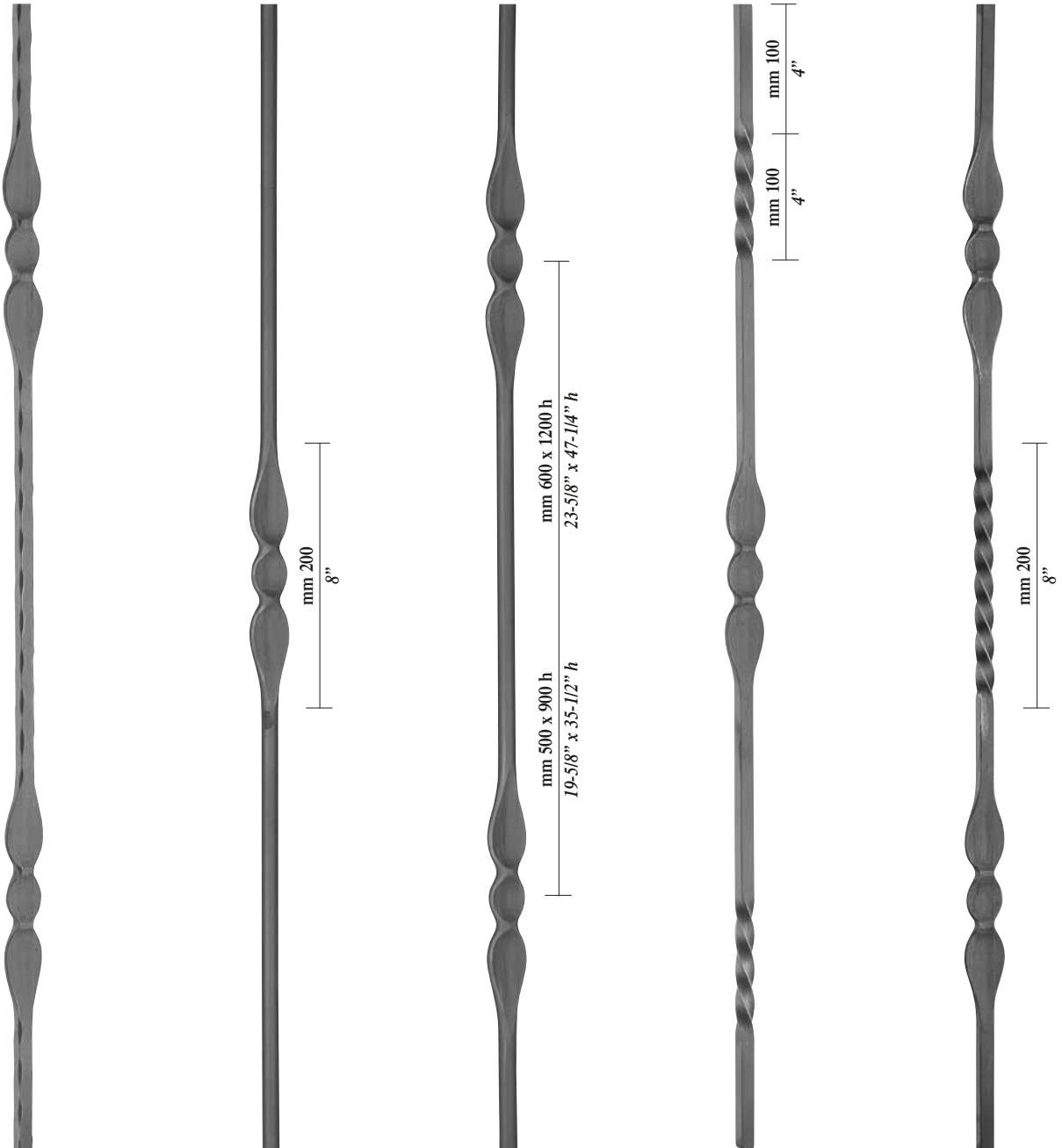

mm 900 h	35-1/2" h	mm 900 h	35-1/2" h	mm 900 h	35-1/2" h	mm 900 h	35-1/2" h	mm 900 h	35-1/2" h
8025-025B	▲ ■ 12 1/2"	8026-045	● 12 1/2"	8025-045	● 12 1/2"	8026-025A	■ 12 1/2"	8025-025A	■ 12 1/2"
8025-026B	▲ ■ 14 9/16"	8026-046	● 14 9/16"	8025-046	● 14 9/16"	8026-026A	■ 14 9/16"	8025-026A	■ 14 9/16"
		mm 1200 h	47-1/4" h	mm 1200 h	47-1/4" h	mm 1200 h	47-1/4" h	mm 1200 h	47-1/4" h
		8026-245	● 12 1/2"	8025-245	● 12 1/2"	8026-225A	■ 12 1/2"	8025-225A	■ 12 1/2"
		8026-246	● 14 9/16"	8025-246	● 14 9/16"	8026-226A	■ 14 9/16"	8025-226A	■ 14 9/16"
mm 1200 h	47-1/4" h								
8025-225B	▲ ■ 12 1/2"								
8025-226B	▲ ■ 14 9/16"								



 *Martellato*  
Hammered

 *Rifinito a caldo*  
Hot finished

 *Forgiato a mano*  
Hand forged

*Particolare finitura*  
Finish detail

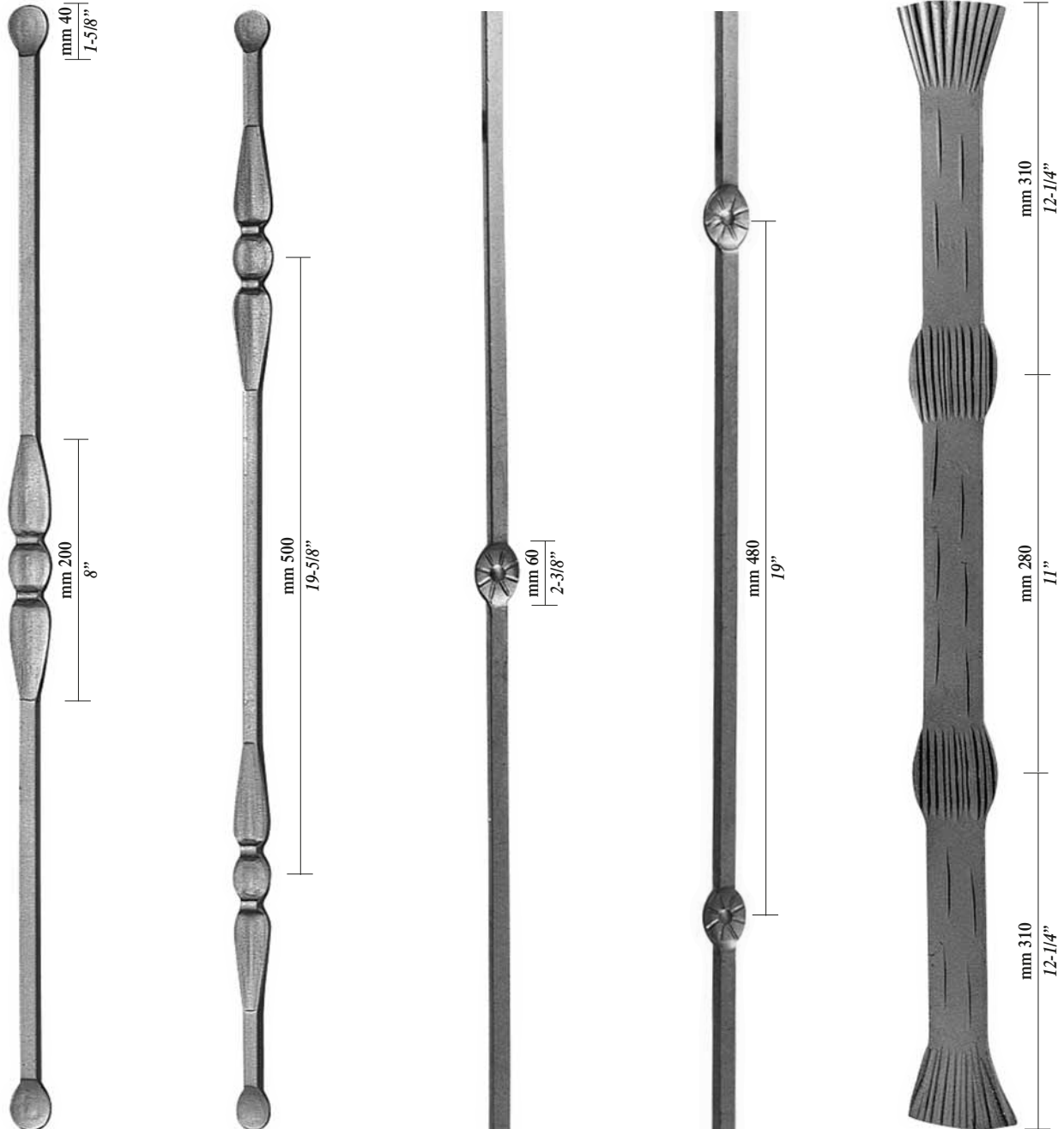

mm 900 h	35-1/2" h
8031	■ 12 1/2"
8033	■ 14 9/16"
mm 1200 h	47-1/4" h
8031-225	■ 12 1/2"
8031-226	■ 14 9/16"

mm 900 h	35-1/2" h
8030	■ 12 1/2"
8032	■ 14 9/16"
mm 1200 h	47-1/4" h
8030-225	■ 12 1/2"
8030-226	■ 14 9/16"

mm 900 h	35-1/2" h
8036	■ 14 9/16"

mm 900 h	35-1/2" h
8035	■ 14 9/16"

mm 900 h	35-1/2" h
8038	■ 50 x 4 1-15/16" x 1/8"

■ *Ferro pieno quadro*  
Square iron

■ *Ferro pieno piatto*  
Flat iron

● *Ferro pieno tondo*  
Round iron

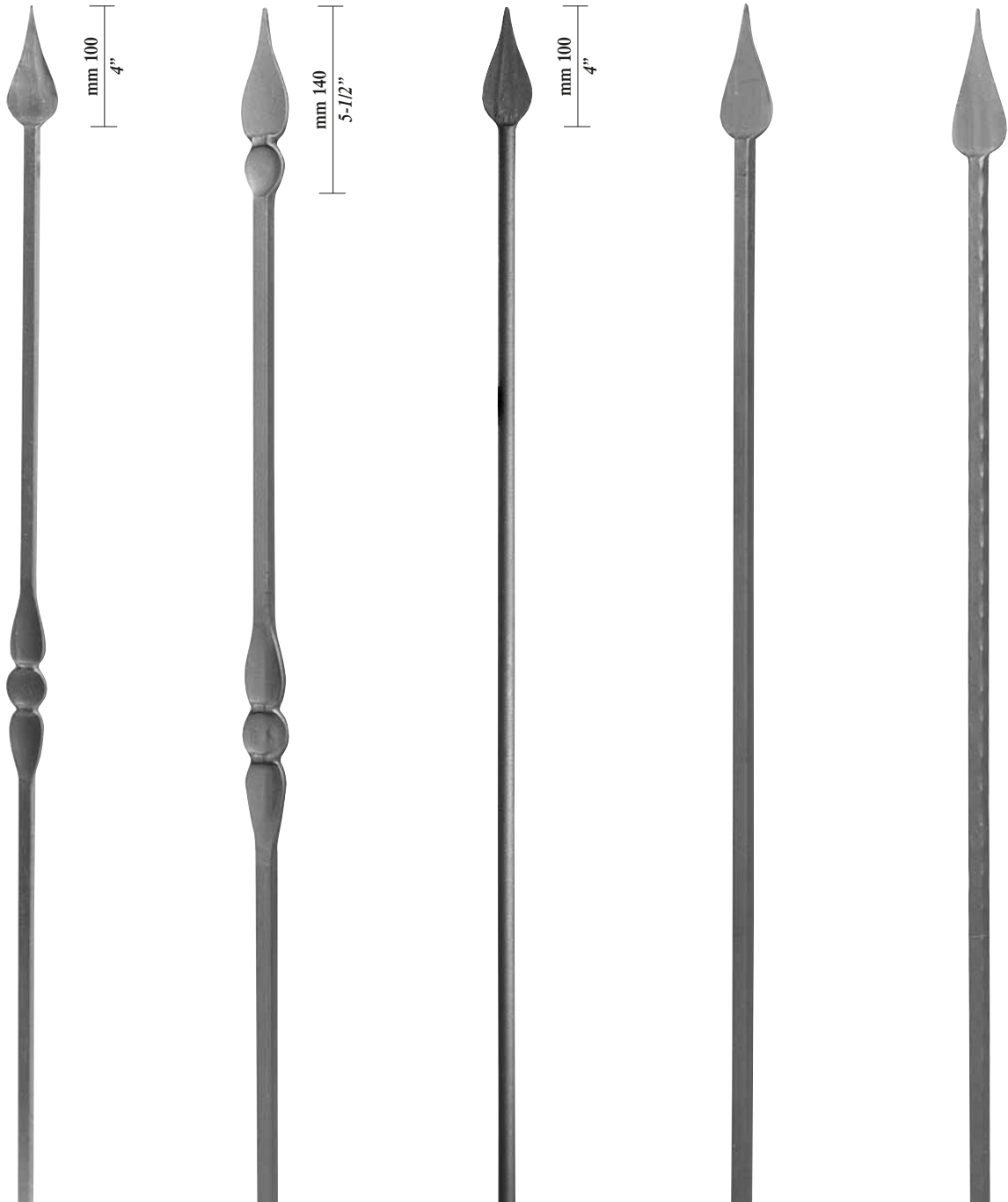

8.2

■ 12 1/2"

8040	800 h	31-1/2" h
8041	1000 h	39-3/8" h
8042	1200 h	47-1/4" h
8043	1500 h	59" h

■ 14 9/16"

8045	800 h	31-1/2" h
8046	1000 h	39-3/8" h
8047	1200 h	47-1/4" h
8048	1500 h	59" h

■ 16 5/8"

8040-527	1500 h	59" h
8040-927	2000 h	78-3/4" h

■ 12 1/2"

8050	800 h	31-1/2" h
8051	1000 h	39-3/8" h
8052	1200 h	47-1/4" h
8053	1500 h	59" h

■ 14 9/16"

8055	800 h	31-1/2" h
8056	1000 h	39-3/8" h
8057	1200 h	47-1/4" h
8058	1500 h	59" h

■ 16 5/8"

8050-527	1500 h	59" h
8050-927	2000 h	78-3/4" h

● 12 1/2"

8060-045	800 h	31-1/2" h
8060-145	1000 h	39-3/8" h
8060-245	1200 h	47-1/4" h
8060-545	1500 h	59" h

● 14 9/16"

8060	800 h	31-1/2" h
8061	1000 h	39-3/8" h
8062	1200 h	47-1/4" h
8063	1500 h	59" h

● 16 5/8"

8060-547	1500 h	59" h
8060-947	2000 h	78-3/4" h

■ 12 1/2"

8065	800 h	31-1/2" h
8066	1000 h	39-3/8" h
8067	1200 h	47-1/4" h
8068	1500 h	59" h

■ 14 9/16"

8070	800 h	31-1/2" h
8071	1000 h	39-3/8" h
8072	1200 h	47-1/4" h
8073	1500 h	59" h

■ 16 5/8"

8060-527	1500 h	59" h
8060-927	2000 h	78-3/4" h

◀ ■ 12 1/2"

8060-025B	800 h	31-1/2" h
8060-125B	1000 h	39-3/8" h
8060-225B	1200 h	47-1/4" h
8060-525B	1500 h	59" h

◀ ■ 14 9/16"

8075	800 h	31-1/2" h
8076	1000 h	39-3/8" h
8077	1200 h	47-1/4" h
8078	1500 h	59" h

◀ ■ 16 5/8"

8060-527B	1500 h	59" h
8060-927B	2000 h	78-3/4" h

PALETTI CON LANCE A FIAMMA  
BALUSTERS WITH STAMPED FLAME SHAPE SPEARHEADS 8.2

 *Martellato*  
Hammered

 *Rifinito a caldo*  
Hot finished

 *Forgiato a mano*  
Hand forged

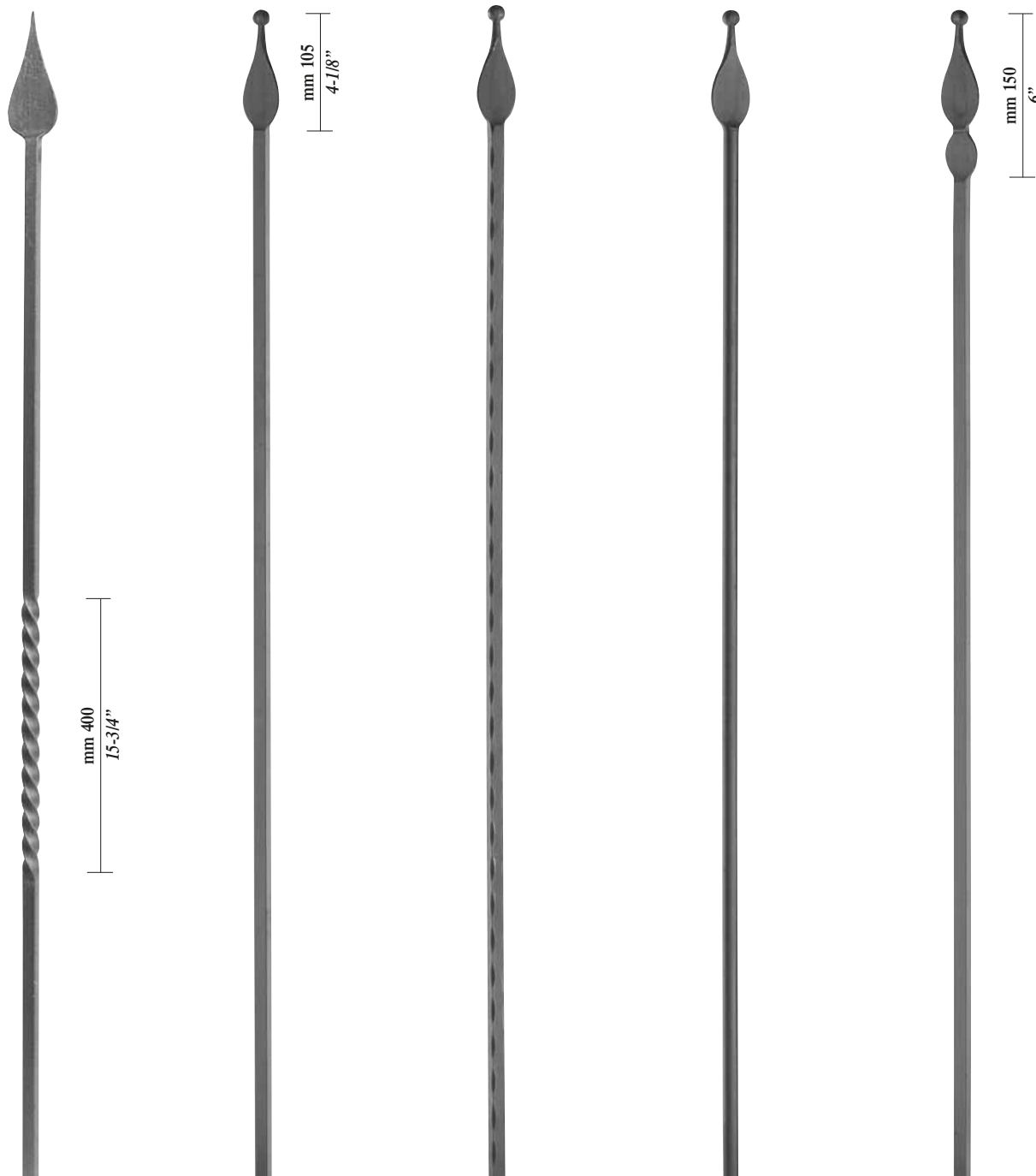

*Particolare finitura*  
Finish detail



8.2

■ 12 1/2"		
8080	800 h	31-1/2" h
8081	1000 h	39-3/8" h
8082	1200 h	47-1/4" h
8083	1500 h	59" h
■ 14 9/16"		
8085	800 h	31-1/2" h
8086	1000 h	39-3/8" h
8087	1200 h	47-1/4" h
8088	1500 h	59" h
■ 16 5/8"		
8080-527	1500 h	59" h
8080-927	2000 h	78-3/4" h

■ 12 1/2"		
8090-025	800 h	31-1/2" h
8090-125	1000 h	39-3/8" h
8090-225	1200 h	47-1/4" h
8090-525	1500 h	59" h
■ 14 9/16"		
8090-026	800 h	31-1/2" h
8090-126	1000 h	39-3/8" h
8090-226	1200 h	47-1/4" h
8090-526	1500 h	59" h
■ 16 5/8"		
8090-527	1500 h	59" h
8090-927	2000 h	78-3/4" h

 ■ 12 1/2"		
8090-025B	800 h	31-1/2" h
8090-125B	1000 h	39-3/8" h
8090-225B	1200 h	47-1/4" h
8090-525B	1500 h	59" h
 ■ 14 9/16"		
8090-026B	800 h	31-1/2" h
8090-126B	1000 h	39-3/8" h
8090-226B	1200 h	47-1/4" h
8090-526B	1500 h	59" h
 ■ 16 5/8"		
8090-527B	1500 h	59" h
8090-927B	2000 h	78-3/4" h

● 12 1/2"		
8090-045	800 h	31-1/2" h
8090-145	1000 h	39-3/8" h
8090-245	1200 h	47-1/4" h
8090-545	1500 h	59" h
● 14 9/16"		
8090-046	800 h	31-1/2" h
8090-146	1000 h	39-3/8" h
8090-246	1200 h	47-1/4" h
8090-546	1500 h	59" h
● 16 5/8"		
8090-547	1500 h	59" h
8090-947	2000 h	78-3/4" h

■ 12 1/2"		
8091-025	800 h	31-1/2" h
8091-125	1000 h	39-3/8" h
8091-225	1200 h	47-1/4" h
8091-525	1500 h	59" h
■ 14 9/16"		
8091-026	800 h	31-1/2" h
8091-126	1000 h	39-3/8" h
8091-226	1200 h	47-1/4" h
8091-526	1500 h	59" h
■ 16 5/8"		
8091-527	1500 h	59" h
8091-927	2000 h	78-3/4" h

■ *Ferro pieno quadro*  
Square iron

■ *Ferro pieno piatto*  
Flat iron

● *Ferro pieno tondo*  
Round iron

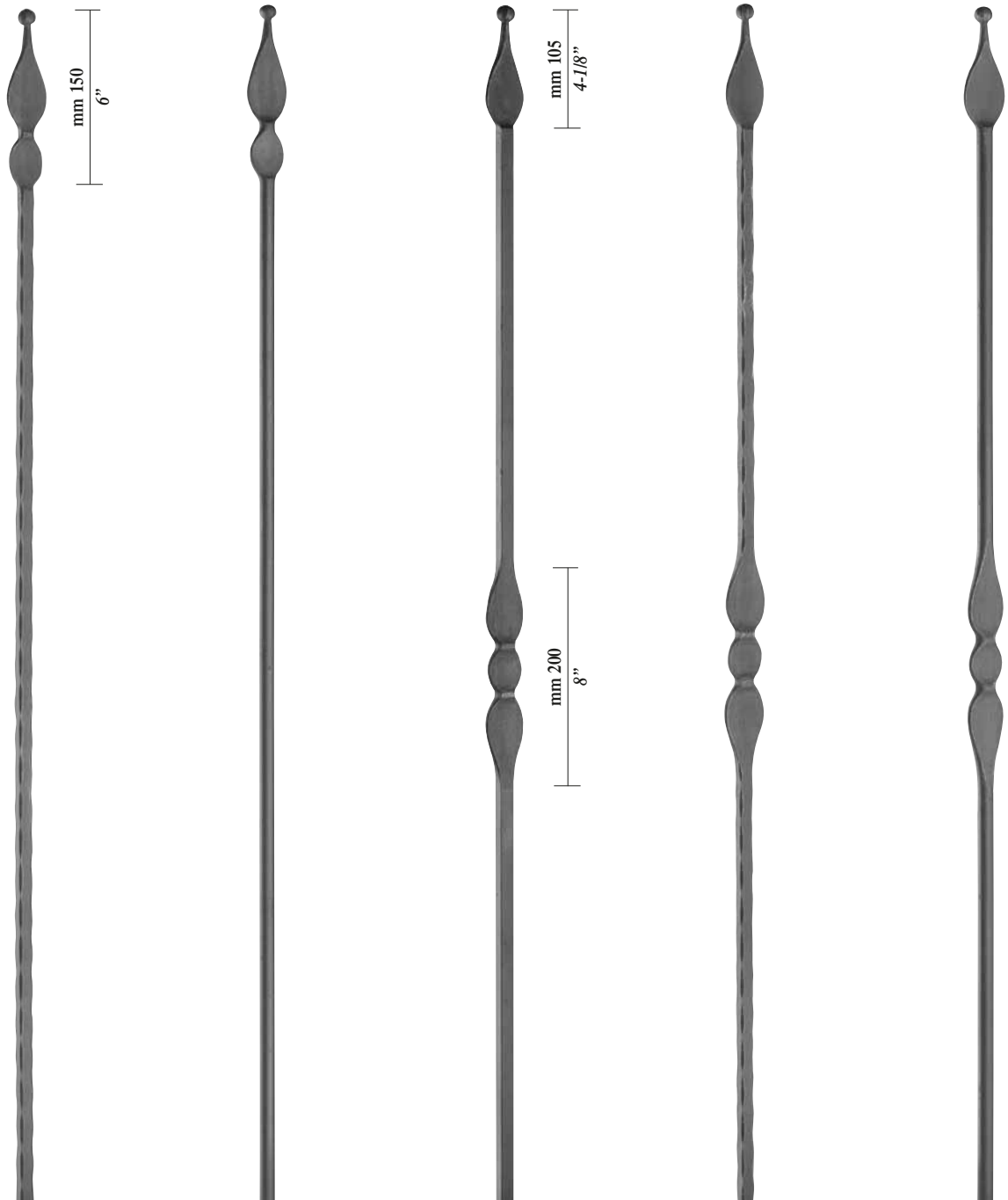

8.2

↙ ■ 12 1/2"

8091-025B	800 h	31-1/2" h
8091-125B	1000 h	39-3/8" h
8091-225B	1200 h	47-1/4" h
8091-525B	1500 h	59" h

↙ ■ 14 9/16"

8091-026B	800 h	31-1/2" h
8091-126B	1000 h	39-3/8" h
8091-226B	1200 h	47-1/4" h
8091-526B	1500 h	59" h

↙ ■ 16 5/8"

8091-527B	1500 h	59" h
8091-927B	2000 h	78-3/4" h

● 12 1/2"

8091-045	800 h	31-1/2" h
8091-145	1000 h	39-3/8" h
8091-245	1200 h	47-1/4" h
8091-545	1500 h	59" h

● 14 9/16"

8091-046	800 h	31-1/2" h
8091-146	1000 h	39-3/8" h
8091-246	1200 h	47-1/4" h
8091-546	1500 h	59" h

● 16 5/8"

8091-547	1500 h	59" h
8091-947	2000 h	78-3/4" h

■ 12 1/2"

8092-025	800 h	31-1/2" h
8092-125	1000 h	39-3/8" h
8092-225	1200 h	47-1/4" h
8092-525	1500 h	59" h

■ 14 9/16"

8092-026	800 h	31-1/2" h
8092-126	1000 h	39-3/8" h
8092-226	1200 h	47-1/4" h
8092-526	1500 h	59" h

■ 16 5/8"

8092-527	1500 h	59" h
8092-927	2000 h	78-3/4" h

↙ ■ 12 1/2"

8092-025B	800 h	31-1/2" h
8092-125B	1000 h	39-3/8" h
8092-225B	1200 h	47-1/4" h
8092-525B	1500 h	59" h

↙ ■ 14 9/16"

8092-026B	800 h	31-1/2" h
8092-126B	1000 h	39-3/8" h
8092-226B	1200 h	47-1/4" h
8092-526B	1500 h	59" h

↙ ■ 16 5/8"

8092-527B	1500 h	59" h
8092-927B	2000 h	78-3/4" h

● 12 1/2"

8092-045	800 h	31-1/2" h
8092-145	1000 h	39-3/8" h
8092-245	1200 h	47-1/4" h
8092-545	1500 h	59" h

● 14 9/16"

8092-046	800 h	31-1/2" h
8092-146	1000 h	39-3/8" h
8092-246	1200 h	47-1/4" h
8092-546	1500 h	59" h

● 16 5/8"

8092-547	1500 h	59" h
8092-947	2000 h	78-3/4" h

 *Martellato*  
Hammered

 *Rifinito a caldo*  
Hot finished

 *Forigato a mano*  
Hand forged

*Particolare finitura*  
Finish detail

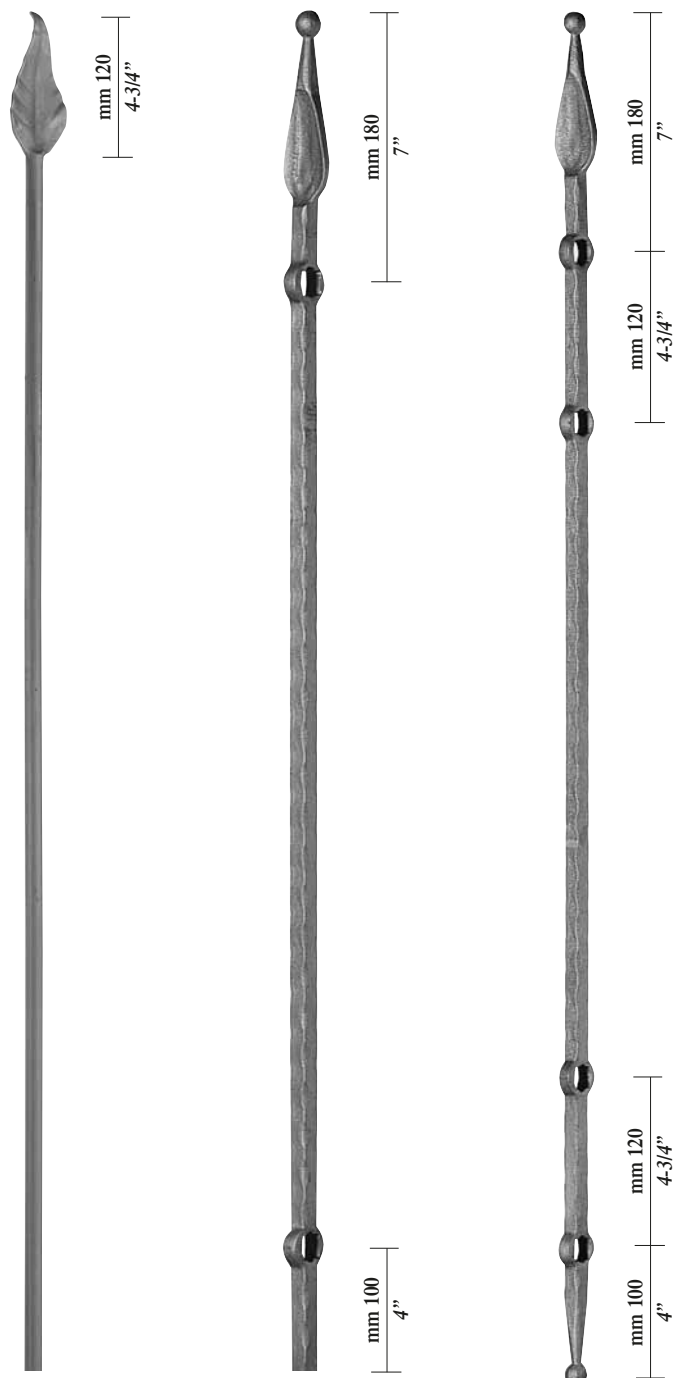

● 12 1/2"

**8095-145** 1000 h 39-3/8" h  
**8095-545** 1500 h 59" h

■ 14 9/16"

**8430** 1000 h 39-3/8" h  
**8431** 1200 h 47-1/4" h  
**8430-526** 1500 h 59" h

◀ ■ 14 9/16"

**8435** 1000 h 39-3/8" h  
**8436** 1200 h 47-1/4" h  
**8430-526B** 1500 h 59" h

■ 14 9/16"

**8440** 1000 h 39-3/8" h  
**8441** 1200 h 47-1/4" h  
**8440-526** 1500 h 59" h

◀ ■ 14 9/16"

**8445** 1000 h 39-3/8" h  
**8446** 1200 h 47-1/4" h  
**8440-526B** 1500 h 59" h



■ Ferro pieno quadro  
Square iron

■ Ferro pieno piatto  
Flat iron

● Ferro pieno tondo  
Round iron

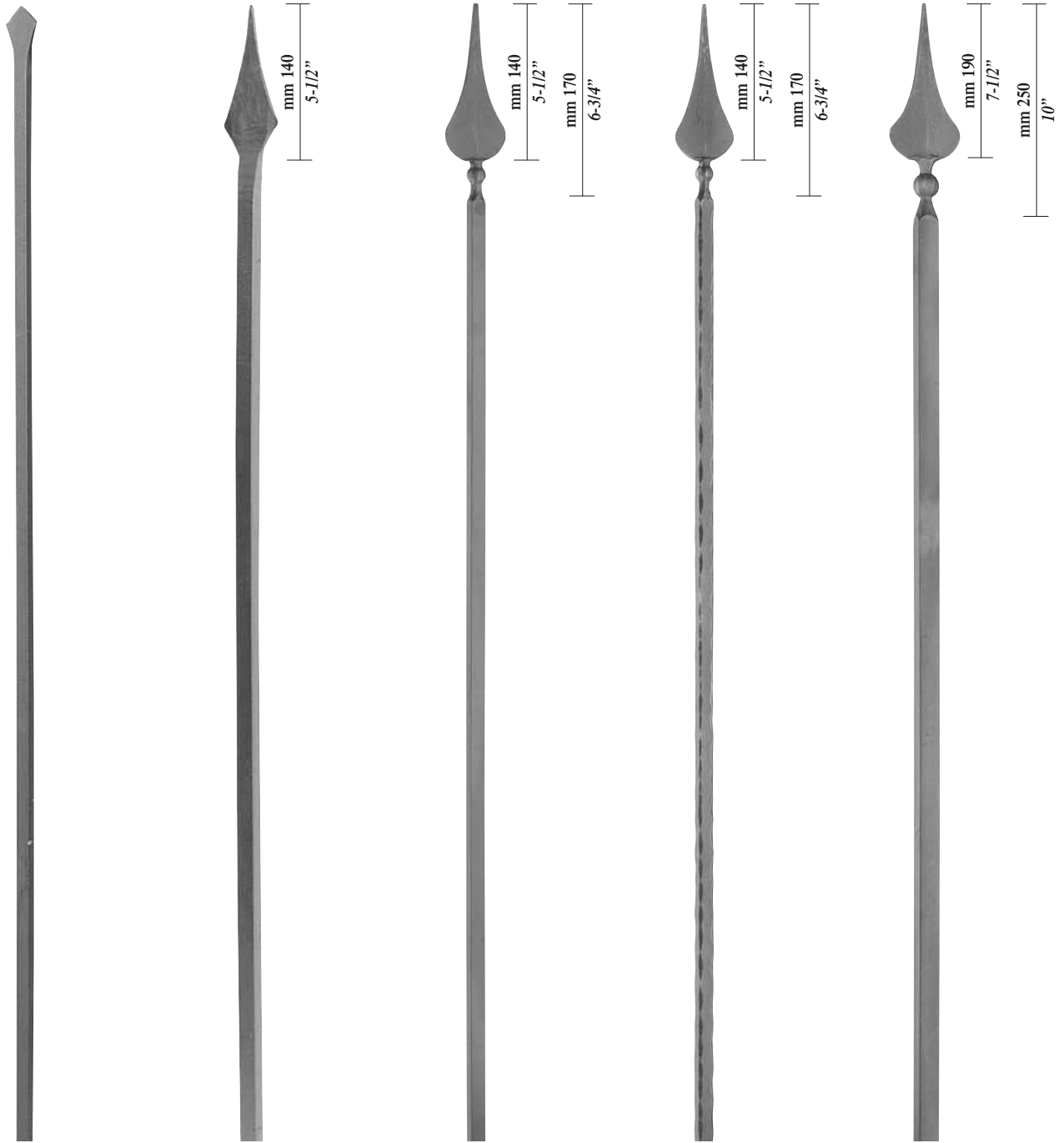

8.2

■ 12 1/2"

8098-125 1000 h 39-3/8" h  
8098-225 1200 h 47-1/4" h

■ 14 9/16"

8098-126 1000 h 39-3/8" h  
8098-226 1200 h 47-1/4" h  
8098-526 1500 h 59" h

■ 16 5/8"

8098-527 1500 h 59" h  
8098-927 2000 h 78-3/4" h

☞ ■ 14 9/16"

8100 1000 h 39-3/8" h  
8101 1200 h 47-1/4" h  
8102 1500 h 59" h

☞ ■ 16 5/8"

8105 1200 h 47-1/4" h  
8106 1500 h 59" h  
8100-927 2000 h 78-3/4" h

☞ ■ 14 9/16"

8110-226 1200 h 47-1/4" h  
8110-526 1500 h 59" h

☞ ■ 16 5/8"

8110-527 1500 h 59" h  
8110-927 2000 h 78-3/4" h

☞ ■ 14 9/16"

8110-226B 1200 h 47-1/4" h  
8110-526B 1500 h 59" h

☞ ■ 16 5/8"

8110-527B 1500 h 59" h  
8110-927B 2000 h 78-3/4" h

☞ ■ 25 1"

8110-531 1500 h 59" h  
8110-831 1800 h 71" h

☞ ■ 25 1"

8110-531B 1500 h 59" h  
8110-831B 1800 h 71" h

PALETTI CON LANCE FORGIATE  
BALUSTERS WITH FORGED SPEARHEADS 8.2









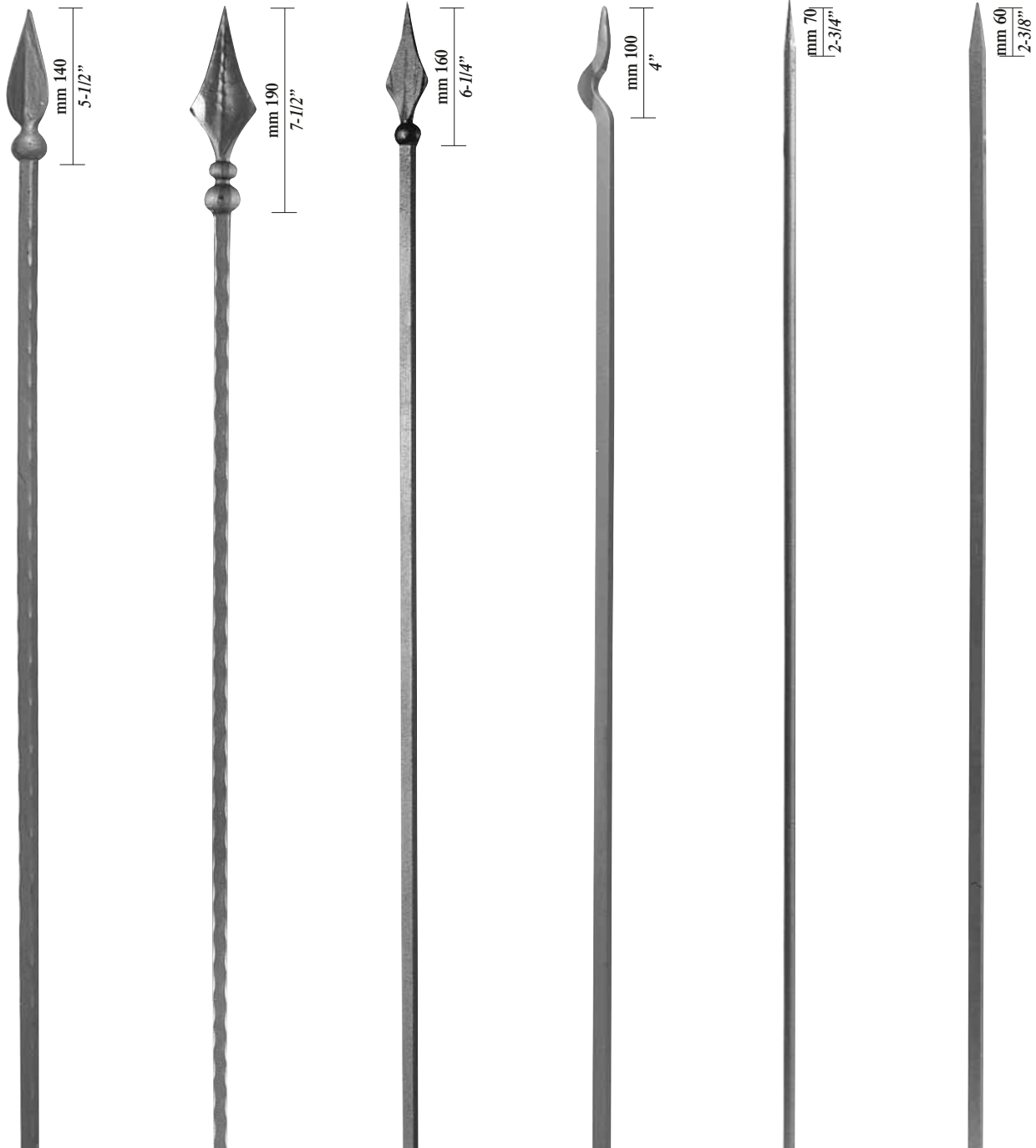





















 *Martellato*  
Hammered

 *Rifinito a caldo*  
Hot finished

 *Forgiato a mano*  
Hand forged

*Particolare finitura*  
Finish detail



mm 1200 h 47-1/4" h	mm 1200 h 47-1/4" h	mm 1200 h 47-1/4" h	mm 1200 h 47-1/4" h	mm 1200 h 47-1/4" h	mm 1200 h 47-1/4" h
8115 ■ 14 9/16"	8120 ■ 14 9/16"	8123 ■ 14 9/16"	8125  ■ 14 9/16"	8130  ● 12 1/2"	8135  ■ 12 1/2"
8117  ■ 14 9/16"	8122  ■ 14 9/16"	8124  ■ 14 9/16"	8125-226B  ■ 14 9/16"	8131  ● 14 9/16"	8136  ■ 14 9/16"
				8132  ● 16 5/8"	8137  ■ 16 5/8"
mm 1500 h 59" h	mm 1500 h 59" h	mm 1500 h 59" h	mm 1500 h 59" h	mm 1500 h 59" h	mm 1500 h 59" h
8115-526 ■ 14 9/16"	8120-526 ■ 14 9/16"	8123-526 ■ 14 9/16"	8125-526 ■ 14 9/16"	8130-545  ● 12 1/2"	8130-525  ■ 12 1/2"
8115-526B  ■ 14 9/16"	8120-526B  ■ 14 9/16"	8123-526B  ■ 14 9/16"	8125-526B  ■ 14 9/16"	8130-546  ● 14 9/16"	8130-526  ■ 14 9/16"
8115-527 ■ 16 5/8"	8120-527 ■ 16 5/8"	8123-527 ■ 16 5/8"	8125-527 ■ 16 5/8"	8130-547  ● 16 5/8"	8130-527  ■ 16 5/8"
8115-527B  ■ 16 5/8"	8120-527B  ■ 16 5/8"	8123-527B  ■ 16 5/8"	8125-527B  ■ 16 5/8"		
mm 2000 h 78-3/4" h	mm 2000 h 78-3/4" h	mm 2000 h 78-3/4" h	mm 2000 h 78-3/4" h	mm 2000 h 78-3/4" h	mm 2000 h 78-3/4" h
8115-927 ■ 16 5/8"	8120-927 ■ 16 5/8"	8123-927 ■ 16 5/8"	8125-927 ■ 16 5/8"	8130-947  ● 16 5/8"	8130-927  ■ 16 5/8"
8115-927B  ■ 16 5/8"	8120-927B  ■ 16 5/8"	8123-927B  ■ 16 5/8"	8125-927B  ■ 16 5/8"		

■ *Ferro pieno quadro*  
Square iron

■ *Ferro pieno piatto*  
Flat iron

● *Ferro pieno tondo*  
Round iron

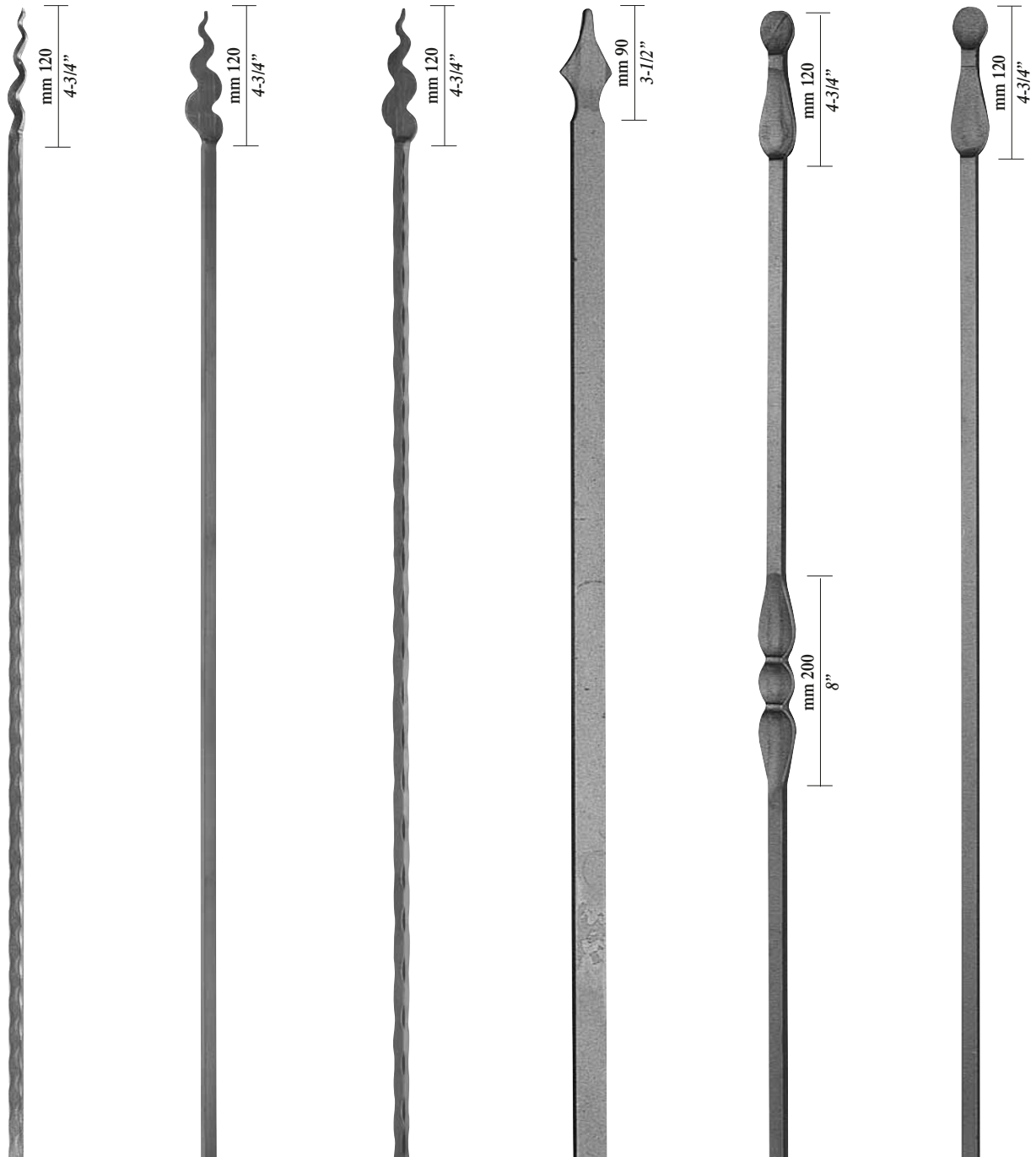

8.2

mm 1200 h 47-1/4" h	mm 1200 h 47-1/4" h	mm 1200 h 47-1/4" h	■ 25 x 8 1"x 5/16"	■ 12 1/2"	■ 12 1/2"
8140 ■ 14 9/16"	8145-226 ■ 14 9/16"	8145-226B ◀ ■ 14 9/16"	8150 180 h 7" h	8170 1000 h 39-3/8" h	8180 1000 h 39-3/8" h
8142 ◀ ■ 14 9/16"			8151 1200 h 47-1/4" h	8171 1200 h 47-1/4" h	8181 1200 h 47-1/4" h
			8152 1500 h 59" h	8172 1500 h 59" h	8182 1500 h 59" h
			8153 3000 h 118-1/8" h		
mm 1500 h 59" h	mm 1500 h 59" h	mm 1500 h 59" h	■ 30x8 1-3/16"x5/16"	■ 14 9/16"	■ 14 9/16"
8140-526 ■ 14 9/16"	8145-526 ■ 14 9/16"	8145-526B ◀ ■ 14 9/16"	8160 180 h 7" h	8175 1000 h 39-3/8" h	8185 1000 h 39-3/8" h
8140-526B ◀ ■ 14 9/16"	8145-527 ■ 16 5/8"	8145-527B ◀ ■ 16 5/8"	8161 1200 h 47-1/4" h	8176 1500 h 59" h	8186 1500 h 59" h
8140-527 ■ 16 5/8"			8162 1500 h 59" h	8177 2000 h 78-3/4" h	8187 2000 h 78-3/4" h
8140-527B ◀ ■ 16 5/8"			8163 3000 h 118-1/8" h		
mm 2000 h 78-3/4" h	mm 2000 h 78-3/4" h	mm 2000 h 78-3/4" h		◀ ■ 14 9/16"	◀ ■ 14 9/16"
8140-927 ■ 16 5/8"	8145-927 ■ 16 5/8"	8145-927B ◀ ■ 16 5/8"		8170-126B 1000h 39-3/8" h	8195 1000 h 39-3/8" h
8140-927B ◀ ■ 16 5/8"				8170-526B 1500h 59" h	8196 1500 h 59" h
				8170-926B 2000h 78-3/4" h	8197 2000 h 78-3/4" h

 *Martellato*  
Hammered

 *Rifinito a caldo*  
Hot finished

 *Forgiato a mano*  
Hand forged

*Particolare finitura*  
Finish detail

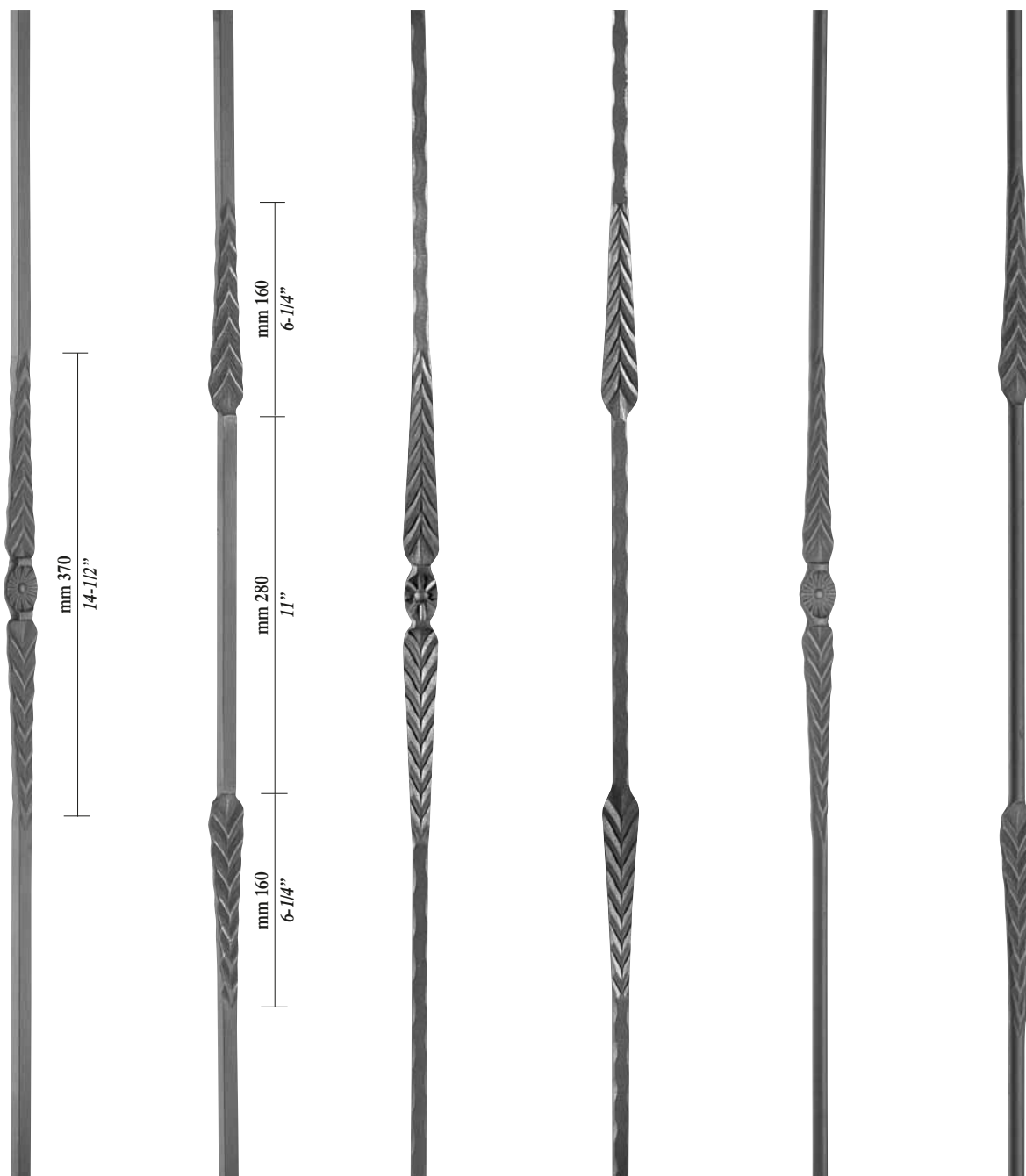

mm 30 x 900 h 1-3/16"x 35-1/2" h		mm 30 x 900 h 1-3/16"x 35-1/2" h		mm 30 x 900 h 1-3/16"x 35-1/2" h		mm 30 x 900 h 1-3/16"x 35-1/2" h		mm 30 x 900 h 1-3/16"x 35-1/2" h		mm 30 x 900 h 1-3/16"x 35-1/2" h	
8210-025	■ 12 5/16"	8205-025	■ 12 5/16"	8210	▲ ■ 12 5/16"	8205	▲ ■ 12 5/16"	8210-045	● 12 5/16"	8205-045	● 12 5/16"
8210-026	■ 14 9/16"	8205-026	■ 14 9/16"	8211	▲ ■ 14 9/16"	8206	▲ ■ 14 9/16"	8210-046	● 14 9/16"	8205-046	● 14 9/16"

■ *Ferro pieno quadro*  
Square iron

■ *Ferro pieno piatto*  
Flat iron

● *Ferro pieno tondo*  
Round iron

8.3

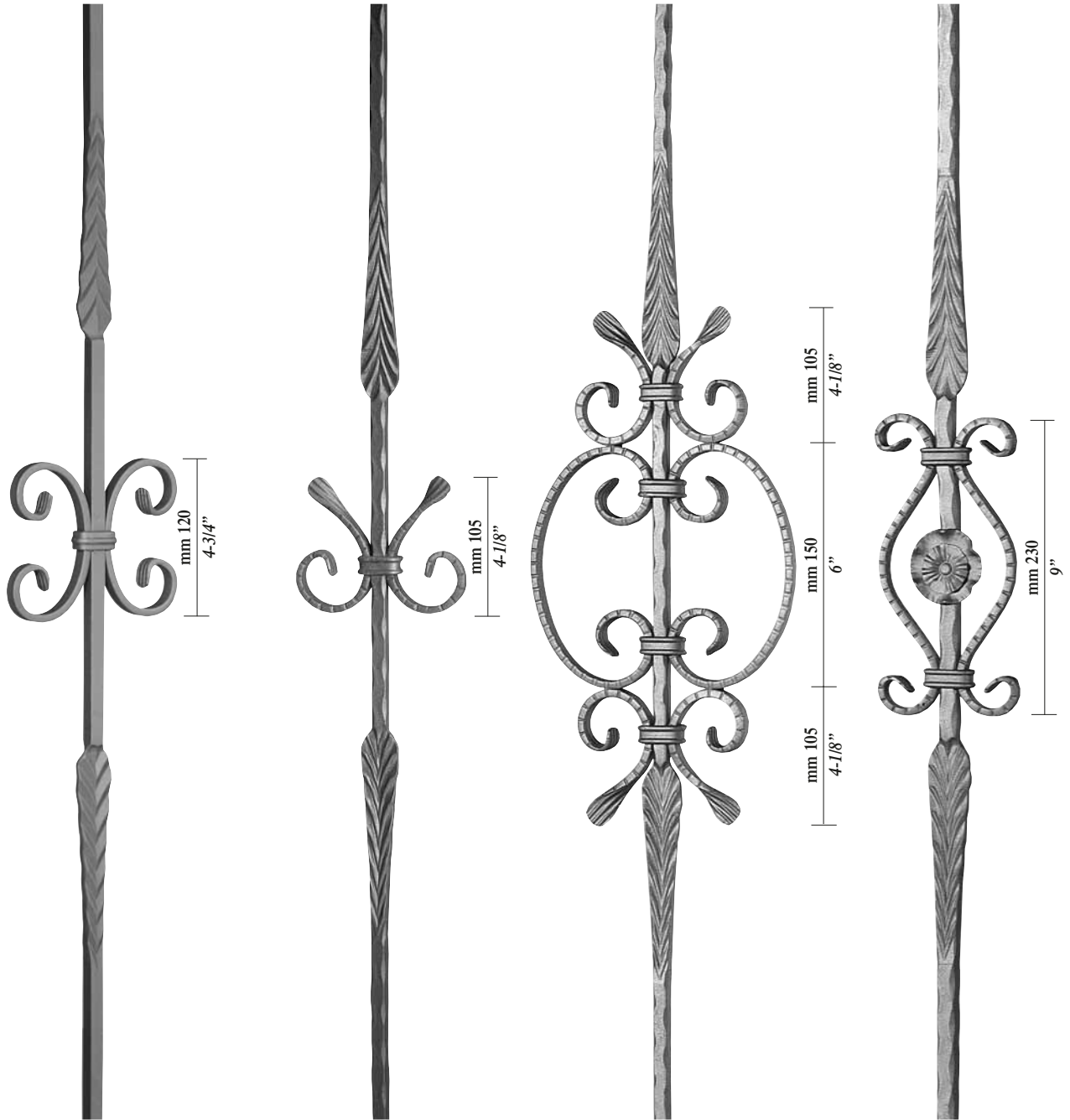

mm 130 x 850 h  
5-1/8" x 33-1/2" h

8214-025 ■ 12 x 6 1/2" x 1/4"  
■ 12 1/2"

mm 140 x 900 h  
5-1/2" x 35-1/2" h

8215 ↙ ■ 12 x 6 1/2" x 1/4"  
↘ ■ 12 1/2"  
8216 ↙ ■ 12 x 6 1/2" x 1/4"  
↘ ■ 14 9/16"

mm 210 x 900 h  
8-1/4" x 35-1/2" h

8220 ↙ ■ 12 x 6 1/2" x 1/4"  
↘ ■ 12 1/2"

mm 110 x 900 h  
4-3/8" x 35-1/2" h

8225 ↙ ■ 12 x 6 1/2" x 1/4"  
↘ ■ 12 1/2"  
8226 ↙ ■ 12 x 6 1/2" x 1/4"  
↘ ■ 14 9/16"



 *Martellato*  
Hammered

 *Rifinito a caldo*  
Hot finished

 *Forgiato a mano*  
Hand forged

*Particolare finitura*  
Finish detail

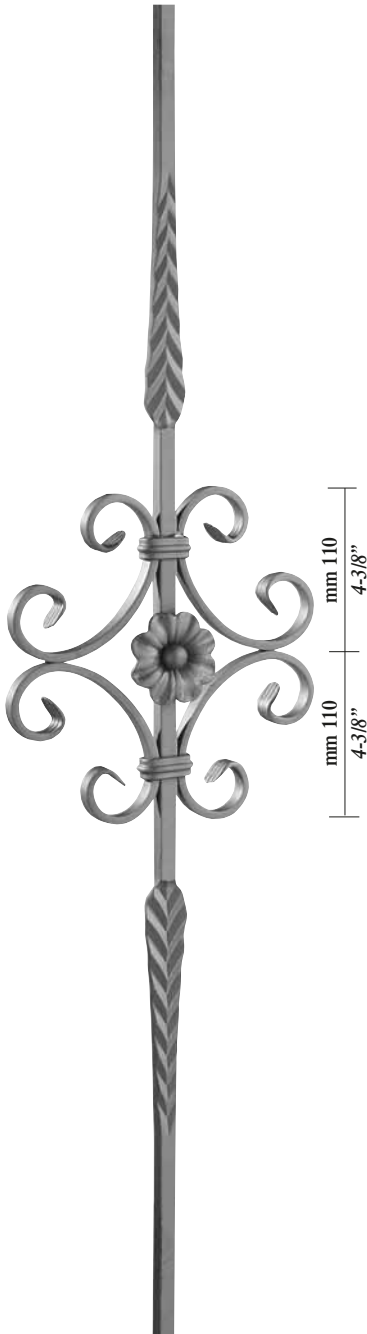

mm 210 x 900 h 8-1/4" x 35-1/2" h		
8230-025	■ 12 x 6	1/2" x 1/4"
	■ 12	1/2"
8230-026	■ 12 x 6	1/2" x 1/4"
	■ 14	9/16"

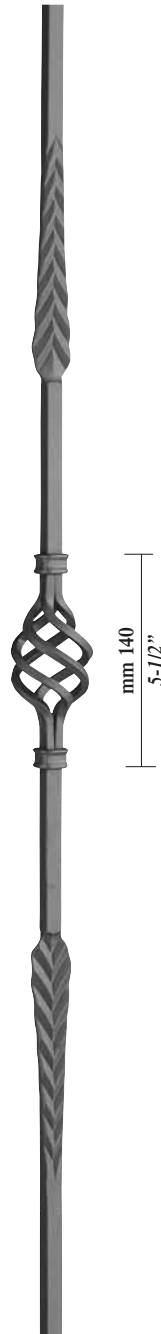

mm 60 x 900 h 2-3/8" x 35-1/2" h		
8235-025	■ 12	1/2"
8235-026	■ 14	9/16"

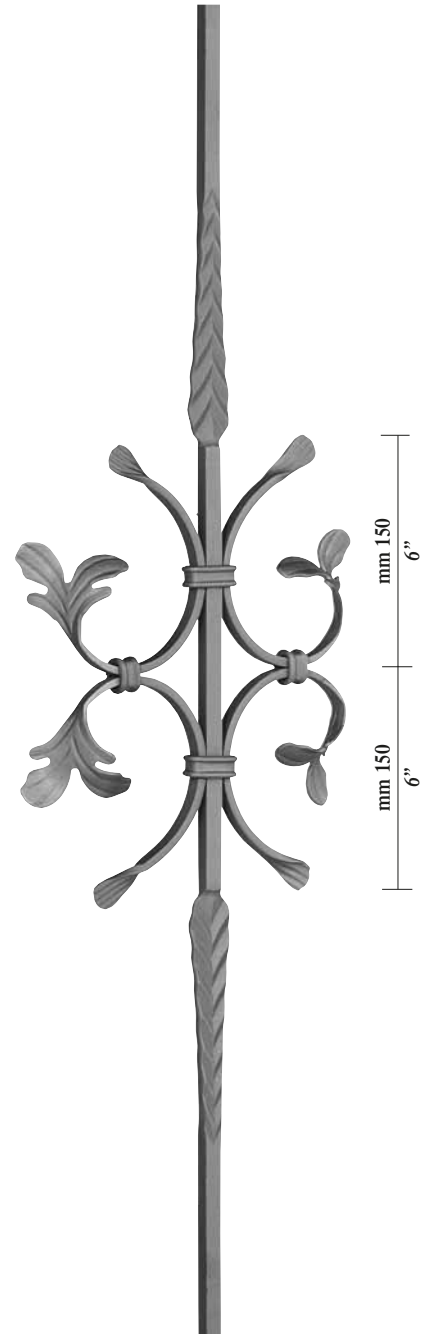

mm 250 x 900 h 9-7/8" x 35-1/2" h		
8240-025	■ 12	1/2"

■ *Ferro pieno quadro*  
Square iron

■ *Ferro pieno piatto*  
Flat iron

● *Ferro pieno tondo*  
Round iron

8.3



● 14 9/16"

<b>9300</b>	820 h	32-1/4" h
<b>9301</b>	900 h	35-1/2" h



● 14 9/16"

<b>9305</b>	820 h	32-1/4" h
<b>9306</b>	900 h	35-1/2" h



■ 14 9/16"

<b>9310</b>	↙ 820 h	32-1/4" h
<b>9311</b>	↘ 900 h	35-1/2" h



<b>8250</b>	■ 12	1/2"
-------------	------	------

 *Martellato*  
Hammered

 *Rifinito a caldo*  
Hot finished

 *Forgiato a mano*  
Hand forged

*Particolare finitura*  
Finish detail

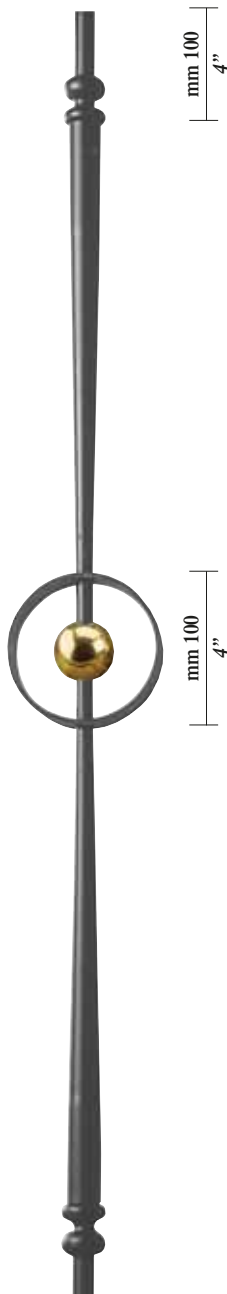

mm Ø 100 x 900 h  
4"x 35-1/2"h

8300 ● 12 1/2"

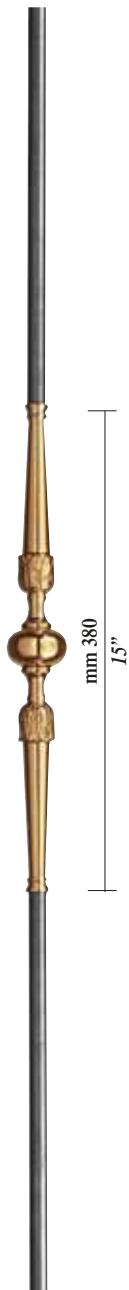

mm Ø 45 x 1000 h  
1-3/4"x39-3/8"h

8310 ● 12 1/2"

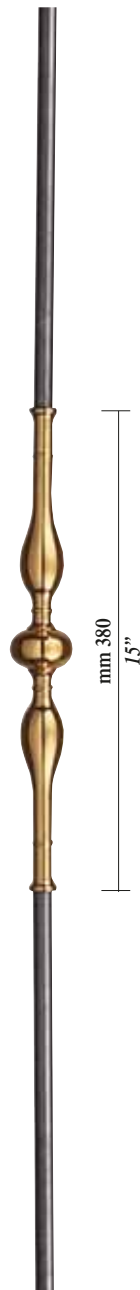

mm Ø 45 x 1000 h  
1-3/4"x39-3/8"h

8312 ● 12 1/2"

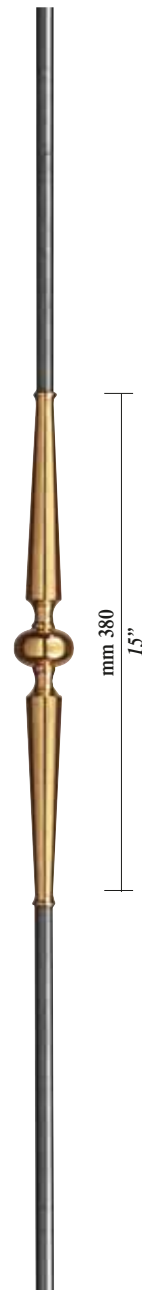

mm Ø 45 x 1000 h  
1-3/4"x39-3/8"h

8315 ● 12 1/2"

