

Duravit AG
Werderstr. 36
78132 Hornberg
Germany
Phone +49 7833 70 0
Fax +49 7833 70 289
info@duravit.com
www.duravit.com

Leben im Bad
Living bathrooms



2nd floor

Preview Edition

Austria

Duravit Österreich
Industriezentrum NÖ-Süd,
Straße 2a/M38
A-2355 Wiener Neudorf
info@at.duravit.com
www.duravit.at

Belgium/Luxemburg

Duravit BeLux S.p.r.l./B.v.b.a.
83, Rue des Combattants
1310 La Hulpe - Belgium
Phone +32 2 6560510
Fax +32 2 6560515
info@be.duravit.com
www.duravit.be

China

Duravit Shanghai Sales Center
Suite B-D
10/F Jiushi Tower
No. 28 Zhongshan Nan Road
Shanghai P.C. 200010
Phone +86 21 33020227
Fax +86 21 63304807
info@cn.duravit.com
www.duravit.com

CIS

Duravit CIS
Repr. Office Moscow
Petrovka 27, Office 245
Moscow 10 70 31
Phone +7 095 937 5553
Fax +7 095 937 5557
info@ru.duravit.com
www.duravit.com

Czech Republic/Slovakia

Duravit CZ
Jungmannova 2
669 02 Znojmo
Phone +420 515 220 155
Fax +420 515 220 154
duravit.cz@tiscali.cz
www.duravit.com

Denmark

Duravit Danmark
Jegstrupvej 6
8361 Hasselager
Phone +45 8626 6000
Fax +45 8626 6001
info@dk.duravit.com
www.duravit.com

Egypt

Duravit Egypt
20, Salah Salem Street
Heliopolis - Cairo
Phone +2 02 4175631
Fax +2 02 4153702
duravit.egypt@eg.duravit.com
www.duravit.com

France

Duravit S.A.
Route de Marienthal B.P.30010
67241 Bischwiller Cedex
Phone N° Indigo +33 820 820 414
Fax +33 388 906 101
info@fr.duravit.com
www.duravit.fr

Hungary

Duravit Hungary
Panoráma u. 30.
2083 Sotymár
Phone +36 26 564465
Fax +36 26 564466
info@hu.duravit.com
www.duravit.com

India

Duravit AG, Germany
India Liaison Office
B - 703, Shapath - 4,
Opp. Karnavati Club,
Nr. Chimanbhai Patel Institute,
Sarkhej Gandhinagar Highway,
Ahmedabad - 380 051,
Gujarat, India
info@in.duravit.com
www.duravit.com

Italy

Duravit Italia S.R.L.
Via Faentina 213
48010 Fornace Zarattini (RA)
Phone +39 0544 509711
Fax +39 0544 501694
info@it.duravit.com
www.duravit.it

Middle East

Duravit Middle East S.A.L.
(OFF SHORE)
P.O. Box 13-6055
Chouran-Beirut 1102-2090
Lebanon
Phone +961 1 397330
Fax +961 1 397329
info@lb.duravit.com
www.duravit.com

Netherlands

Duravit Nederland B.V.
Ruwekampweg 2
5222 AT 's-Hertogenbosch
Phone +31 73 6131970
Fax +31 73 6100983
info@nl.duravit.com
www.duravit.com

Poland

Duravit Poland
ul. Krasynskiego 74/11
71-447 Szczecin
Phone +48 604 544 588
Fax +48 914 316 323
info@pl.duravit.com
www.duravit.com

Portugal

Duravit Portugal
Rua Antoine de Saint-Exupéry
Alaprala
2765-043 Estoril
Phone +351 21 466 7110
Fax +351 21 466 7119
duravit@jrb.pt
www.duravit.com

Singapore and South East Asia

Duravit Singapore
#15-20, Block 16
River Valley Close
Singapore 238433
Phone +65 6733 1748
Fax +65 6735 7548
www.duravit.com

Spain

Duravit España S.L.
Logística, 18
Pol. Ind. Sector Z
08150 Parets del Valles
(Barcelona)
Phone +34 902 387 700
Fax +34 902 387 711
info@es.duravit.com
www.duravit.es

Switzerland

Duravit Vertrieb Schweiz:
Keramik Laufen AG
Wahlenstrasse 46
4242 Laufen
Phone +41 61 7657575
Fax +41 61 7615711
info@center@laufen.ch
www.duravit.com

Turkey

Duravit Yapı Ürünleri San.ve Tic. A.Ş.
Organize Deri Sanayi Bölgesi
10. Yol 1-4 Parsel
34956 Tuzla/Istanbul
Phone +90 216 4585151
Fax +90 216 4585195
info@tr.duravit.com
www.duravit.com.tr

United Kingdom

Duravit UK, Limited
Unit 7 Stratus Park
Brudenell Drive, Brinklow
Milton Keynes, MK10 0DE
Phone +44 870 7307787
Fax +44 870 7307786
info@uk.duravit.com
www.duravit.co.uk

USA

Duravit USA, Inc.
1750 Breckinridge Parkway
Suite 500
Duluth, GA 30096
Phone +1 770 9313575
Fax +1 770 9318454
info@usa.duravit.com
www.duravit.us

Best-Nr. 001244/05-01.06.5.1 - Printed in Germany - We reserve the right to make technical improvements and enhance the appearance of the products shown.





Das Bad auf einer neuen Ebene. Essen, Schlafen, Arbeiten, Leben: „Wohnen“ ist, wenn auch unmerklich, einer permanenten Veränderung unterworfen. Und wie auf alle andere Bereiche des Zuhauses hat sich auch der Blick auf das Bad gewandelt. So wird das Bad heute nicht mehr als separater, isolierter Raum betrachtet, sondern als Teil eines offenen Ganzen. Als ein Ort, der vielen Anforderungen genügen muss. Als ein Ort, der sich auf seinen Benutzer einstellt und nicht umgekehrt – ebenso funktional wie wohnlich, ebenso einladend wie persönlich. Veränderungen, die nach einem passenden Badprogramm verlangen. Hier ist es: 2nd floor. Entworfen von Sieger Design und realisiert von Duravit, gibt 2nd floor neue Impulse in der modernen Badgestaltung. Willkommen auf einer neuen Ebene. Willkommen im 2nd floor.

A bathroom on a completely new level. Eating, sleeping, working, living: the way we live is subject to gradual but continual change. And – along with all the other aspects of our homes – our perceptions of the bathroom have changed. The bathroom is no longer seen as a separate, isolated space but as an integral part of an organic and open whole. As a place that needs to meet a range of different needs. As a place that adapts to suit the people who use it, rather than making people adapt to suit it. Functional and friendly, inviting and individual. Meeting these changing requirements calls for the right range of bathroom furniture. Here it is: 2nd floor. Created by Sieger Design and made by Duravit, 2nd floor gives new impetus to contemporary bathroom design. Welcome to a completely new level. Welcome to the 2nd floor.

Il bagno su un nuovo piano. Mangiare, dormire, lavorare, vivere: il concetto di «abitare», anche se in modo impercettibile, è cambiato in maniera irreversibile. E come per tutti gli altri ambienti della casa, anche la concezione del bagno è mutata. Oggi il bagno non è più considerato come uno spazio isolato, separato, ma come parte integrante di un insieme. Uno spazio che deve rispondere a molte esigenze. Uno spazio che si adatta a chi lo utilizza e non viceversa; funzionale quanto confortevole, invitante quanto personale. Tali cambiamenti richiedono una serie per il bagno adatta: 2nd floor. Creata da Sieger Design e prodotta da Duravit, 2nd floor dà nuovo impulso all'arredobagno moderno. Benvenuti su un nuovo piano. Benvenuti a 2nd floor.

La salle de bains franchit un nouveau palier. Manger, dormir, travailler, vivre : «habiter» est une notion en mutation permanente, même si cela est parfois imperceptible. Et comme dans tous les univers de la maison, la vision de la salle de bains a évolué. C'est ainsi que la salle de bains ne se présente plus comme une pièce séparée, mais plutôt comme un élément s'intégrant dans un espace ouvert. Comme un lieu qui doit satisfaire beaucoup d'exigences. Un lieu qui s'adapte à l'utilisateur et non l'inverse – aussi fonctionnel que convivial, aussi accueillant que personnel. Des changements qui exigent une série de salle de bains adaptée. Elle existe : c'est 2nd floor. Créée par Sieger Design et réalisée par Duravit, 2nd floor donne de nouvelles impulsions dans l'aménagement des salles de bains modernes. Bienvenue sur un nouveau palier. Bienvenue au 2nd floor.

De badkamer op een nieuw niveau. Eten, slapen, werken, leven: „wonen“ is, ook als het vaak ongemerkt gebeurt, onderhevig aan permanente verandering. En zoals dat geldt voor de woonomgeving in zijn algemeenheid heeft ook de blik op de badkamer een verandering ondergaan. Zo wordt de badkamer tegenwoordig niet meer beschouwd als aparte, geïsoleerde ruimte, maar als deel van een open geheel. Als een plek die aan veel eisen moet voldoen. Als een plek die zich instelt op zijn gebruiker en niet omgekeerd – even functioneel als behaaglijk, even uitnodigend als persoonlijk. Veranderingen die vragen om een passend badkamerprogramma. En zie hier: 2nd floor. Ontworpen door Sieger Design en gerealiseerd door Duravit, geeft 2nd floor nieuwe impulsen aan een moderne vormgeving van de badkamer. Welkom op een nieuw niveau. Welkom op de 2nd floor.

El baño elevado a un nuevo nivel. Comer, dormir, trabajar, vivir: «habitar» es sometido, si bien casi imperceptible, a unos cambios permanentes. Tal como ocurrió en todos los otros ámbitos de la vivienda, la forma de ver el cuarto de baño también ha cambiado. De esta manera, hoy en día el baño ya no se ve como un espacio separado y aislado, sino parte de un conjunto total y abierto. Como un lugar que debe satisfacer muchas exigencias. Como un lugar que debe adaptarse al usuario y no a la inversa – tanto en un plano funcional como en distribución y debe invitar y ser personal. Cambios que reclaman un programa de baño apropiado. Aquí está: 2nd floor. Diseñado por Sieger Design y realizado por Duravit, 2nd floor proporciona al diseño de baño un nuevo impulso. Bienvenido a un nuevo nivel. Bienvenido a 2nd floor.



Design by Sieger Design



Das Zauberwort bei 2nd floor: wohnlich. Und so ziehen sich durch die komplette Serie warme Holzelemente, die wohl- tuend mit den weißen Keramikoberflächen kontrastieren, wie hier in der Variante Kirschbaum (Dekor). Die Öffnung der Grenze zum Wohnbereich wird unterstrichen durch das große Möbelprogramm. Dank des Variantenreichtums an Waschtischen kann sich der Waschplatz auf alle Bedürfnisse der Badbenutzer einstellen. Und auch bei den Dusch-, Bade- und Whirlwannen passen sich unterschiedlichste Abmessungen an alle räumlichen Gegebenheiten an. Besonders wohnlich wird's durch die verschiedenen Bade- und Duschwannenverkleidungen, die es in allen Holzönen gibt.

The keyword for 2nd floor is welcoming. Throughout the range, warm wooden elements provide a pleasant contrast, perfectly setting off the white ceramic surfaces – as seen here in the cherry décor finish. 2nd floor's extensive range of furniture is central to the way the range transcends the borders between bathroom and living area. The washbasin versions offer a wealth of choice, allowing a washing area to be individually designed to meet its users' every need. The bathtubs, showers and whirlpools, too, come in a wide range of sizes to suit every room layout. The friendly and welcoming appearance wouldn't be complete without the bath and shower panelling, available in all wood colours.

Confortevole è la parola magica di 2nd floor. La serie comprende infatti caldi elementi in legno che contrastano piacevolmente con le superfici bianche della ceramica, qui ad esempio nella tonalità Ciliegio (bilaminato). L'ampia gamma di mobili evidenzia il superamento dei confini del bagno verso lo spazio abitativo. Grazie alla ricchezza di varianti per i lavabi, è possibile soddisfare qualsiasi necessità o desiderio. Anche i piatti doccia e le vasche, con o senza sistema idromassaggio, grazie alle loro diverse dimensioni, si adattano a tutti i tipi di spazio. Un tocco particolare dato poi dai diversi rivestimenti di vasche e piatti doccia, in tutte le tonalità del legno Duravit.

Le mot magique de 2nd floor : la convivialité. C'est ainsi que, dans toute la ligne, la chaleur du bois contraste agréablement avec les éléments céramiques. Comme par exemple la variante en Cerisier (décor). Le riche programme de meubles favorise la transition vers la pièce de séjour. Grâce à la diversité des lavabos, l'espace toilette se conforme exactement aux exigences de l'utilisateur. Il en va de même pour les douches, baignoires et baignoires avec systèmes balnéos dont les dimensions variées se logent dans toutes les configurations. Les divers habillages en bois des baignoires rendent les espaces particulièrement chaleureux.

Het toverwoord bij 2nd floor luidt: behaaglijkheid. En zo is de complete serie doortrokken van warme houtelementen die weldadig contrasteren met de witte keramische oppervlakken, zoals hier in de uitvoering kersen (decor). De opening van de grens naar de woonruimte wordt geaccentueerd door het grote meubelprogramma. Dankzij de enorme diversiteit aan wastafels kan de badkamer worden aangepast aan alle behoeften van de gebruiker. En ook de douchebakken, baden en whirlpoolbaden kunnen dankzij de meest uiteenlopende afmetingen worden ingepast in elke ruimtelijke situatie. Bijzonder gerieflijk wordt het door de diverse ommantelingen voor baden en douchebakken, die verkrijgbaar zijn in alle houttinten.

La palabra clave en 2nd floor: cómodo. Y de esta forma cálidos elementos de madera atraviesan toda la serie que contrasta agradable con la blanca superficie de la cerámica, como aquí en la versión con cerezo (decorado). La apertura de las zonas predeterminadas de la vivienda se subraya mediante un amplio programa de muebles. Gracias a la amplia variedad de los lavabos, el lugar de aseo puede adaptarse a cualquier necesidad de los usuarios. También los platos de ducha, bañeras y bañeras de hidromasaje con sus variadas medidas se adaptan a todas las situaciones de espacio. Los revestimientos de bañeras y platos de ducha, disponibles en todos los acabados de madera dan un toque muy acogedor a cualquier espacio.







It's your life

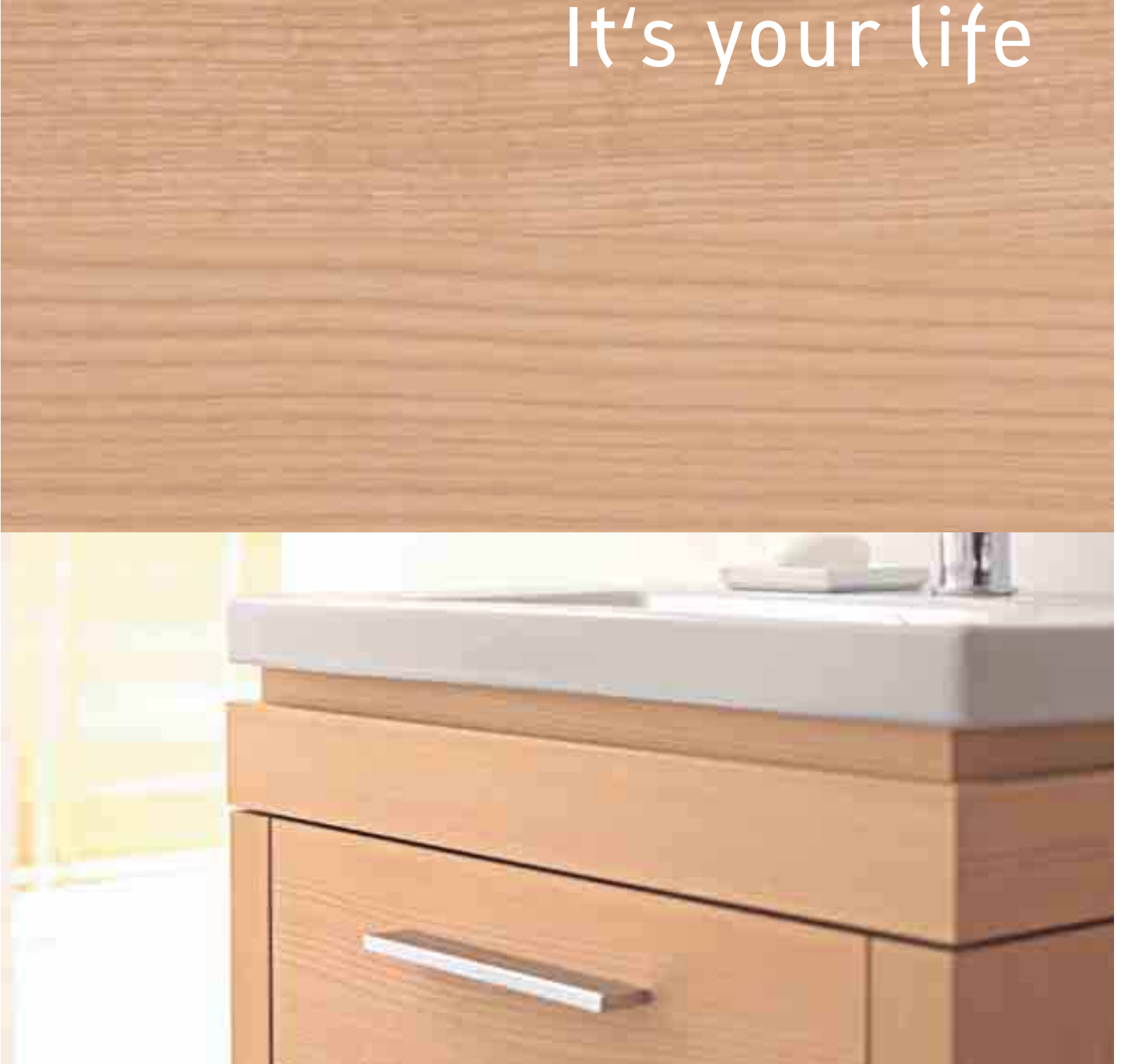





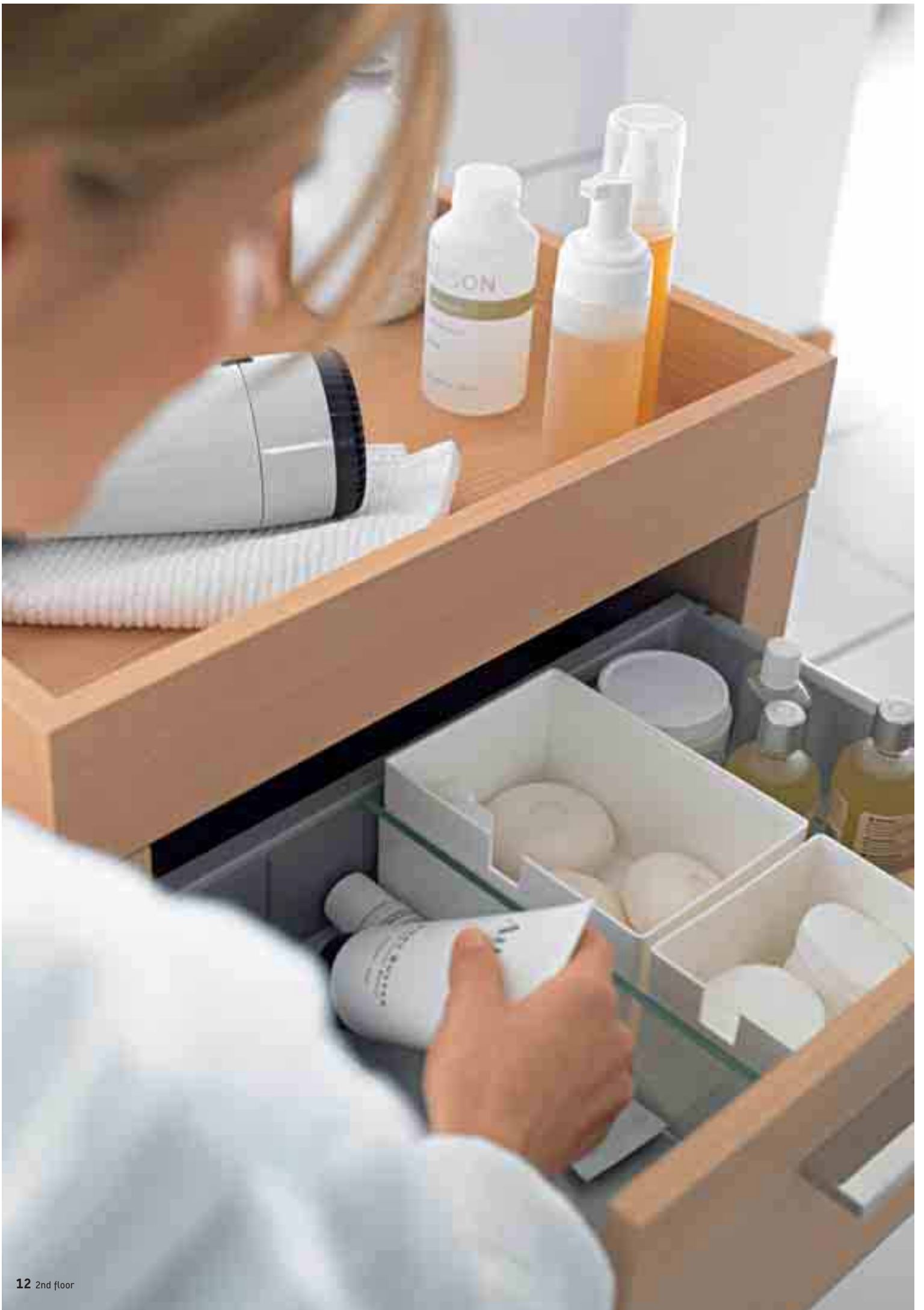



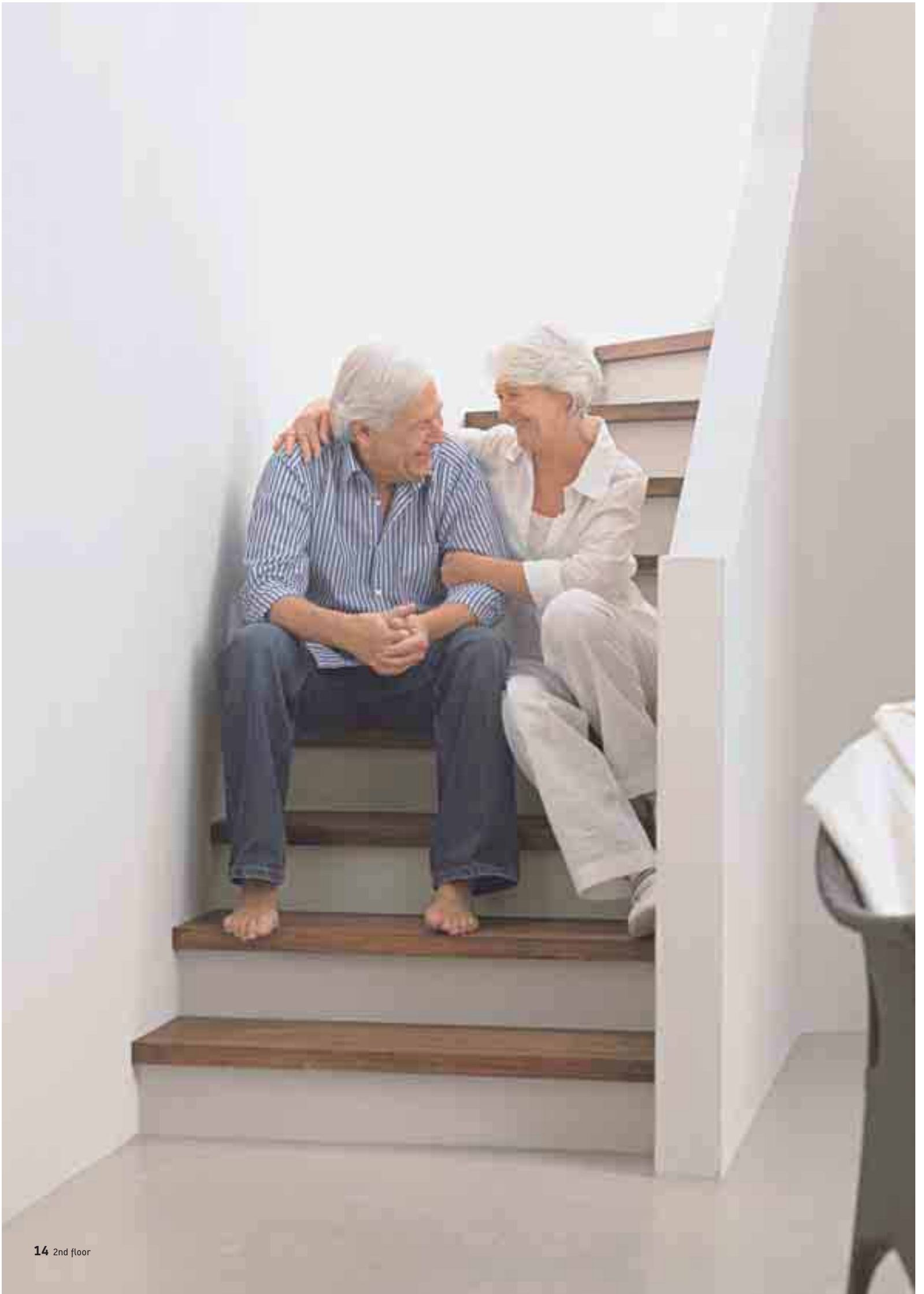

Was hindert uns eigentlich daran, die Dinge einmal aus einer ganz anderen Perspektive zu betrachten? Genau: gar nichts. Bei 2nd floor in Palisander (Dekor) korrespondieren die edlen Holzoberflächen mit der Geradlinigkeit der Keramik – und verwandeln das Bad in einen Raum mit Persönlichkeit. Für viel Komfort sorgt ein reiches Wannenprogramm mit vielen Varianten, ob als Vorwand- oder Einbauversion, ganz freistehend oder mit Stufe und Einstiegshilfe. Komplettiert wird das Bad durch ein aufeinander abgestimmtes, modulares Möbelsystem, das das 2nd-floor-Bad offen hält für jeden Wunsch an Veränderung. Heute, morgen und übermorgen.

What actually prevents us from seeing things from a completely different perspective? Precisely: nothing at all. In 2nd floor in rosewood (décor), the elegant wooden surfaces combine with the clean, straight lines of the ceramics to create a bathroom with its own individual character. The broad range of bathtub options means that 2nd floor is available to suit many different situations. The range includes back-to-wall and built-in versions, either completely free-standing or equipped with a step and safety handrail. The bathroom is completed by a coordinated and modular furniture system, meaning that your 2nd floor bathroom can adapt to meet changing needs and wishes. Now and for a long time to come.

Che cosa ci impedisce di guardare le cose da un punto di vista completamente diverso? Proprio niente. Con 2nd floor in Palissandro (bilaminato), le eleganti superfici del legno rispondono alla linearità della ceramica e trasformano il bagno in un ambiente ricco di personalità. Il comfort è assicurato dalla ricca scelta di vasche nelle diverse varianti, da appoggio a parete o da incasso, a centro stanza o con gradino e maniglione. La serie è completata da un sistema modulare di mobili abbinati che permette a 2nd floor di soddisfare tutti i desideri di cambiamento. Oggi, domani, sempre.

Qu'est-ce qui nous empêche de modifier notre perception des choses ? Rien, très exactement. Avec 2nd floor en finition Palissandre (décor), les élégantes finitions bois correspondent avec le tracé rectiligne de la céramique – et transforment la salle de bains en une pièce affirmant son identité. Un riche programme de baignoires décliné dans diverses variantes procure tout le confort, posées en îlot ou avec un marche-pied et un accès facilité. Un système de meubles modulaires assortis complète la salle de bains, ce qui permet de modifier l'aménagement encore ultérieurement, selon souhait. Aujourd'hui, demain, après-demain.

Wat weerhoudt ons er eigenlijk van de dingen eens vanuit een geheel ander perspectief te bekijken? Precies: helemaal niets. Bij 2nd floor in palissander (decor) corresponderen de exclusieve houtoppervlakken met de rechte lijnigheid van het keramiek – en veranderen ze de badkamer in een ruimte met persoonlijkheid. Voor optimaal comfort zorgt een rijk programma baden met veel varianten, als wanduitvoering of inbouwversie, geheel vrijstaand of met trede en instaphulp. De badkamer wordt aangevuld met een op elkaar afgestemd, modulair meubelsysteem dat de 2nd-floor-badkamer flexibel houdt voor elke veranderingswens. Vandaag, morgen en overmorgen.

¿Que nos impide realmente ver las cosas de una perspectiva completamente diferente? En el fondo, nada. En el 2nd floor en Palisandro (decorado) corresponde el noble acabado de madera con la rectitud de la cerámica y convierte el baño en un espacio con personalidad. Proporciona mucho confort, el amplio programa de bañeras con muchas versiones, tanto como versión delante de la pared o para empotrar, completamente exenta o con peldaños o ayuda para entrar. El baño se complementa con un compaginado sistema de muebles modulares que se mantiene abierto a cualquier deseo de cambio en el baño de 2nd floor. Hoy, mañana y siempre.







Change your view









Hell, freundlich, einladend: Das ist der erste Eindruck von 2nd floor, hier in der Oberfläche Eiche gekalkt (Echtholz-furnier). Bei näherer Betrachtung begeistert die Serie mit ihrer wahrhaft genialen Verschmelzung von Keramik und Holz, von Konsequenz und Vielfalt, von gutem Design und purer Wohnlichkeit. So wirkt z. B. die optionale Innenbeckenbeschichtung in Edelstahl matt wertvoll, bleibt aber dabei absolut pflegeleicht. Überhaupt wurde bei aller Schönheit das Praktische nicht vergessen: Ein gutes Beispiel dafür ist der Wannenauszug, der viel Stauraum für Badutensilien bietet. Aus diesem Zusammenspiel von Verstand und Emotion entsteht eine lebendige Spannung – und macht aus dem Bad eine wahre Wohlfühl-Oase für alle Sinne.

Bright, friendly, inviting – that's the first impression made by 2nd floor. Shown here in limed oak (real wood veneer). A closer look and the range captivates us with its truly brilliant fusion of ceramics and wood, constancy and contrast, excellent design and a unique combination of warmth and practicality. The optional brushed stainless steel interior finish of the basin, for example, is both luxurious and extremely easy to clean. Throughout the range, pleasing looks have been achieved without sacrificing functionality. The bath drawer is a perfect example, providing plenty of storage space for bathroom bits and pieces. This interplay between intellect and emotion creates vivid contrasts – and transforms a bathroom into a veritable oasis, offering something for all the senses.

Chiaro, simpatico, invitante: è la prima impressione che dà 2nd floor. Qui in Rovere sbiancato (impiallacciatura in vero legno). Ad un esame più attento, la serie entusiasma per la geniale fusione di ceramica e legno, di coerenza e molteplicità, di buon design e puro comfort. Ad esempio, la bellissima smaltatura dell'interno del bacino in Acciaio satinato impreziosisce il lavabo senza comprometterne la facilità di pulizia. La bellezza non ha tolto niente alla praticità: ne è un ottimo esempio l'elemento estraibile della vasca, che offre grande capienza per tutti i piccoli oggetti del bagno. Questo gioco di ragione e sentimento crea una viva emozione e rende il bagno una vera e propria oasi di benessere per i sensi.

Clair, convivial, accueillant, voilà les premiers critères caractérisant 2nd floor. Ici la finition Chêne chaulé (bois véritable). Plus précisément, la série enthousiasme par la fusion réussie entre la céramique et le bois, entre l'esprit et la diversité, entre le design de qualité et l'authentique convivialité. C'est ainsi que la finition inox mat à l'intérieur de la cuve affirme son raffinement tout en restant très facile d'entretien. Tant de beauté n'exclut pas les aspects pratiques. Le tiroir de la baignoire en fournit un bon exemple. Il offre beaucoup d'espace à tous les accessoires de toilette. Cette combinaison entre la raison et l'émotion crée une ambiance vivifiante et transforme la salle de bains en une véritable oasis de bien-être pour tous les sens.

Licht, vriendelijk, uitnodigend: dat is de eerste indruk van 2nd floor. Hier in het oppervlak eiken gekalkt (houtfineer). Het geheim van de inspiratie van deze serie zit hem bij nadere beschouwing in de waarlijk geniale versmelting van keramiek en hout, van consequentie en diversiteit, van goede vormgeving en zuivere behaaglijkheid. Zo maakt bijv. de optionele binnen coating van de wastafel in RVS een matte en stijlvolle indruk, maar blijft hij daarbij absoluut onderhoudsvriendelijk. Sowieso is bij alle schoonheid het praktische aspect niet veronachtzaamd: een goed voorbeeld hiervan is de bad-schuiflade, die veel bergruimte biedt voor badkamerbenodigdheden. Uit dit samenspel van verstand en emotie ontstaat een levendige spanning – en maakt van de badkamer een ware feelgood-oase voor alle zintuigen.

Claro, agradable, tentador: Esta es la primera impresión de 2nd floor. Aquí con un acabado en roble blanco (chapa de madera auténtica). Viéndolo más entretenidamente la serie entusiasma fundiendo de forma genial la cerámica y la madera, la consecuencia y la variedad, el buen diseño y la comodidad pura. De esta manera aparece noble, por ejemplo, el recubrimiento opcional del interior de seno en acero inoxidable mate siendo sin embargo muy fácil de limpiar. De hecho, no se ha olvidado el lado práctico con toda esta belleza: un buen ejemplo es el cajón de bañera, que ofrece mucho espacio para utensilios del baño. De esta interacción de razón y emoción se crea una tensión viva que convierte el baño en un oasis de bienestar para todos los sentidos.







What a feeling

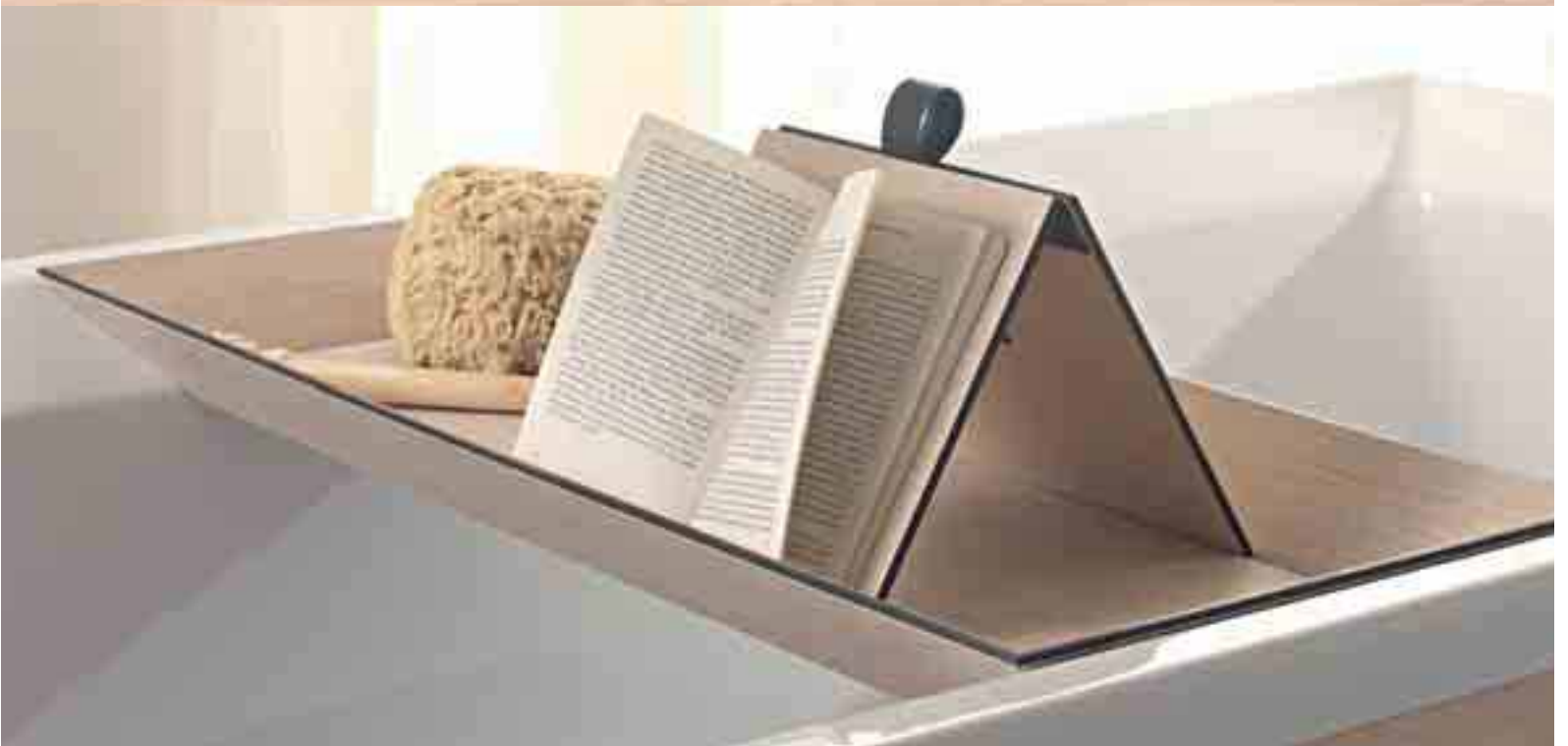



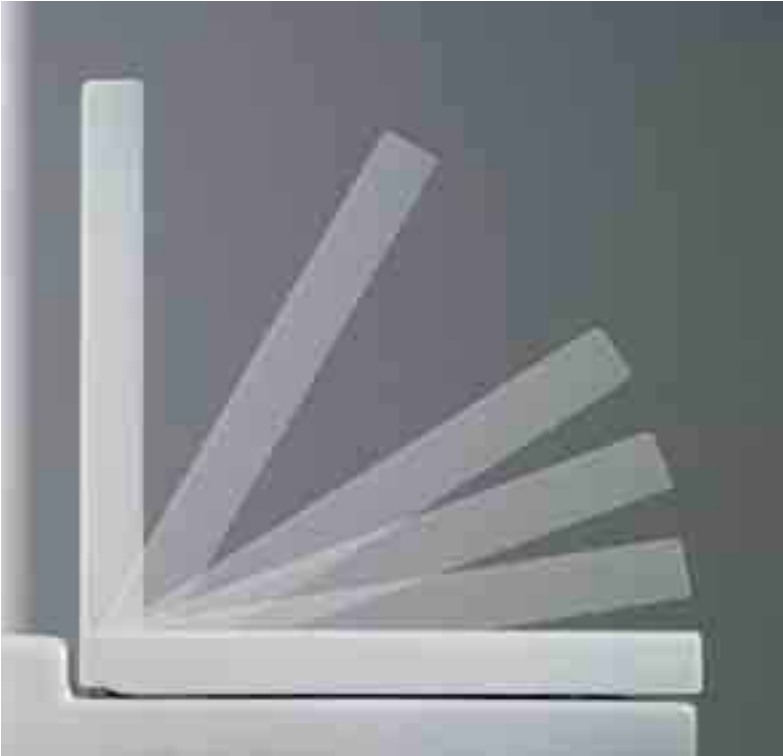











Auch wenn sie aus den 1920ern stammt, hat die Bauhaus-Maxime „Weniger ist mehr“ heute mehr Gültigkeit als je zuvor – dank 2nd floor. Offensichtlich wird das bei der Variante Ebenholz (Echtholz furnier). Sorgsam ausgewählt und eingesetzt, ergeben die Stücke der Serie ein formales und funktionales Bad- und Wohnkonzept, das so viel mehr bietet: mehr Ästhetik, mehr Bequemlichkeit, mehr Lebensqualität. Dafür sorgt auch der völlig neuartige Badewannen-Ablauf: Wie bei der Duschwanne verdeckt durch eine Blende aus Sanitäracryl, wird er durch ein einfaches Draufklicken geöffnet und geschlossen. So ist 2nd floor: Reduziert, aber mit Finesse. Minimalistisch, aber mit Charme. Asketisch, aber mit Vergnügen. Wenn es doch immer so leicht wäre, Verzicht zu üben.

The Bauhaus maxim "less is more" may date back to the 1920s, but it's never been truer than it is today – thanks to 2nd floor. A look at the version in ebony (real wood veneer) makes this absolutely apparent: chosen and combined with care, the pieces in this collection amount to nothing less than a new concept for the bathroom and for living. A concept that unites form and function to offer so much more: more aesthetic appeal, more comfort, more quality of life. Just one example is the completely new outflow design on the baths and showers – concealed by an acrylic cover that opens and closes at a click. That's 2nd floor: design that is at once reduced and refined. Design that is both minimalist and full of charm. Design that combines austerity with downright pleasure. If only it was always this easy to practice restraint.

Anche se risale agli Anni Venti del secolo scorso, la massima del Bauhaus «meno è più» vale ancora più oggi di allora... grazie a 2nd floor. Lo si può vedere nella versione in Ebano (impiallacciatura in vero legno); i pezzi della serie, scelti e posizionati con cura, creano un concetto di bagno/spazio abitativo formale e funzionale, che offre molto di più: più estetica, più comfort, miglior qualità della vita. Ne è un esempio anche il nuovissimo scarico della vasca: nascosto da una lastra in acrilico sanitario come nei piatti doccia, si apre o chiude con una semplice pressione. 2nd floor è così: ridotto all'essenziale, ma estremamente raffinato; minimalista, ma affascinante; ascetico, ma divertente. Magari rinunciare a qualcosa fosse sempre così facile!

Même si elle date des années 20, la maxime issue de l'époque du Bauhaus «less is more» est plus que jamais d'actualité – grâce à 2nd floor. Cela apparaît de manière plus évidente encore dans la version Bois d'ébène (bois véritable). Soigneusement choisies et mises en œuvre, les pièces de la série construisent une salle de bains fonctionnelle et un art de vivre qui transcendent les exigences : davantage d'esthétique, de confort, de qualité de vie. Le nouvel écoulement de la baignoire y contribue également très fortement. Comme dans la douche, il est masqué par un cache en acryl sanitaire qui se fixe et s'enlève par simple clips. C'est ainsi que se définit 2nd floor : réduit, mais avec finesse. Minimaliste, mais avec charme. Ascétique, mais avec plaisir. Si seulement le renoncement était toujours aussi simple.

Ook al stamt hij uit de jaren '20 van de vorige eeuw, het Bauhaus-adagium „Minder is meer“ heeft tegenwoordig meer geldigheid dan ooit tevoren – dankzij 2nd floor. Dit is duidelijk zichtbaar bij de uitvoering ebbenhout (houtfijner): met zorg uitgekozen en verwerkt dragen de stukken uit de serie bij tot een formeel en functioneel badkamer- en woonconcept dat zoveel meer te bieden heeft: meer esthetiek, meer comfort, meer levenskwaliteit. Hiervoor zorgt ook de volledig innovatieve badafvoer: evenals bij de douchebak verborgen door een afschermkap van sanitairacryl, die eenvoudig kan worden geopend en gesloten door erop te klikken. Dat is 2nd floor: sober doch stijlvol. Minimalistisch maar charmant. Ascetisch en toch weldadig. Was het maar altijd zo gemakkelijk om voor eenvoud te gaan.

Aún que provenga del año 1920, la máxima del Bauhaus «menos es más» tiene ésta más que nunca la validez – gracias a 2nd floor. Se pone de evidencia en la versión de ébano (chapa de madera auténtica). Seleccionado y aplicado de forma cuidadosa, la piezas de la serie dan como resultado un concepto funcional y formal de baño y vivienda que ofrece mucho más: más estética, más comodidad, más calidad de vida. De esto se ocupa un desagüe completamente novedoso de la bañera: como en el plato de ducha revestido por un faldón de acrílico sanitario se abre y cierra mediante un simple clic. Así es 2nd floor: reducido pero con sutileza. Minimalista pero con encanto. Estético pero con diversión. Si siempre fuera tan fácil de renunciar.







Less is more







400 mm

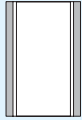

9645

400 mm

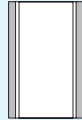

9645

600 mm



9646

600 mm

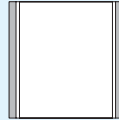

9646

800 mm



9647

1200 mm



9648

1200 mm



9648

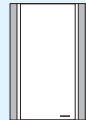

9650 L/R

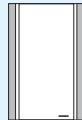

9650 L/R

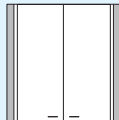

9651

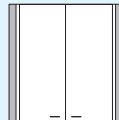

9651

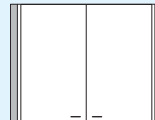

9652

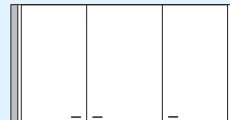

9653

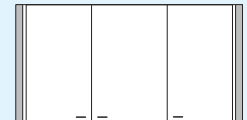

9653

400 mm

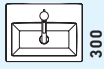

0790400000

500 mm

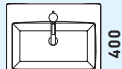

0790500000

600 mm

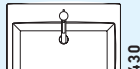

049160..00
049160..30

700 mm

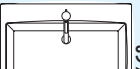

049170..00
049170..30

800 mm

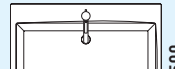

049180..00
049180..30

1200 mm

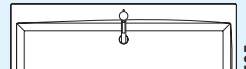

049112..00
049112..30

1200 mm

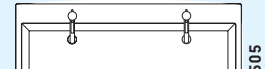

049112..24
049112..30

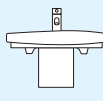
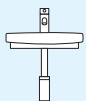

+ # 0857130000

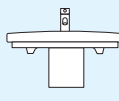

+ # 0857160000

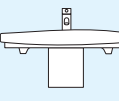

+ # 0857160000

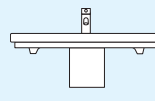

+ # 0857140000

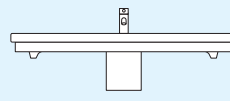

+ # 0857140000

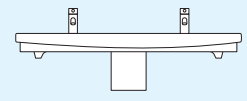

+ # 0857140000

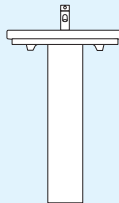

+ # 0863180000

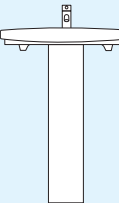

+ # 0863180000

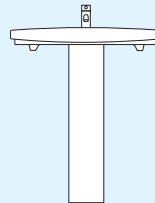

+ # 0863190000

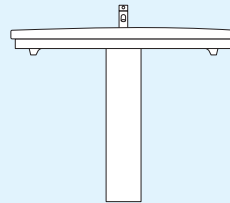

+ # 0863190000

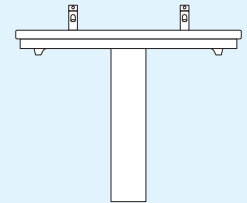

+ # 0863190000

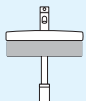

+ # 6405

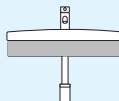

+ # 6406

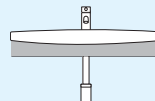

+ # 6407

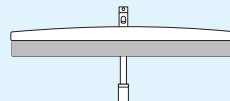

+ # 6408

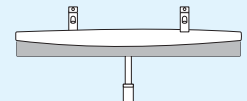

+ # 6408

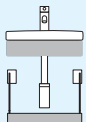

+ # 6405 + # 6440

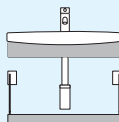

+ # 6406 + # 6441

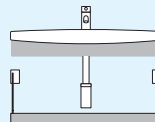

+ # 6407 + # 6442

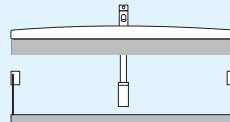

+ # 6408 + # 6443

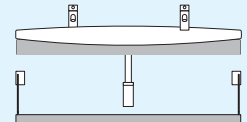

+ # 6408 + # 6443

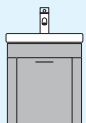

+ # 6445 L/R

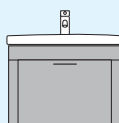

+ # 6446

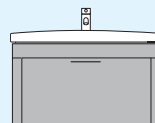

+ # 6447

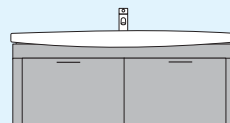

+ # 6448

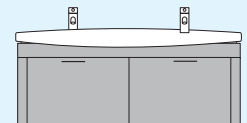

+ # 6448

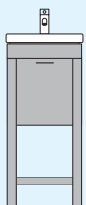

+ # 6455 L/R

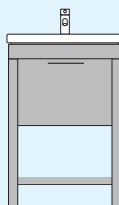

6456

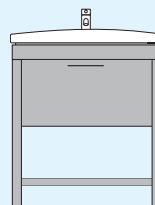

6457

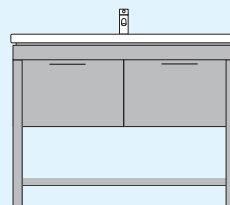

6458

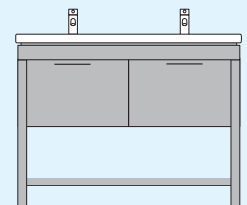

6458

600 mm

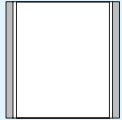

9646

600 mm

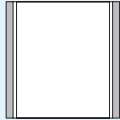

9646

600 mm



9646

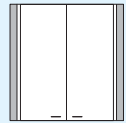

9651

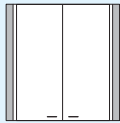

9651

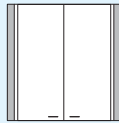

9651

580 mm

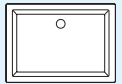

031758..29

555 mm

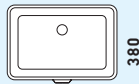

031653..00

580 mm

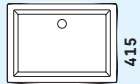

031758..00

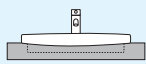

031758..29



031653..00

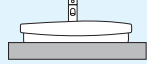

031758..00

500 mm

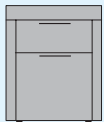

9272 L/R

600 mm

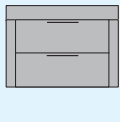

9266

800 mm

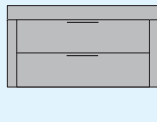

9267

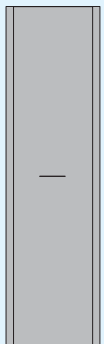

9156 L/R

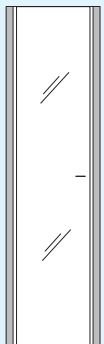

9157 L/R

600 mm

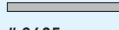

9405

800 mm



9406

1200 mm

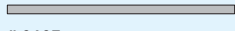

9407

800 - max. 2000 mm

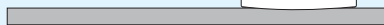

-> # 031758, # 049170, # 049180, # 049112

600 mm

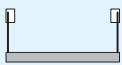

6439

800 mm

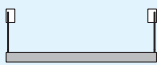

6442

1200 mm

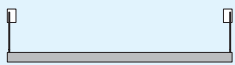

6443

400 mm



9275

600 mm



9276

370 mm

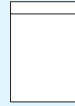

2205090000
+ # 0068990000



0110090000
+ # 0068990000



2107090000
+ # 0876000005/
0876100005
+ # 0068990000

2106090000
+ # 0876000005/
0876100005
+ # 0068990000

370 mm

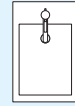

2235150000

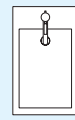

0136100000
0136100030

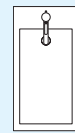

0137100000
0137100030

L/R = Links/Rechts
Left/Right
sinistra/destra
à gauche/à droite
Links/Rechts
izquierda/devecha

1600 x 700 mm



700073
● □ 1



700078
8785 □ 2



700078
8780 □ 2

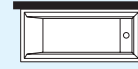

700078
8775 □ 5

1700 x 700 mm



700074
● □ 1



700079
8786 □ 2



700079
8781 □ 2

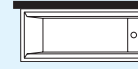

700079
8776 □ 5

1700 x 750 mm



700075
● □ 1



700080
8787 □ 2



700080
8782 □ 2

2090 x 1140 mm

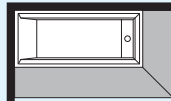

700080
8804 □ 4

2090 x 1140 mm

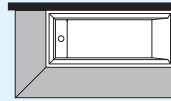

700080
8802 □ 4



700080
8777 □ 5

2090 x 1140 mm

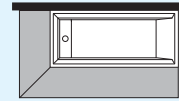

700080
8798 □ 9

1800 x 800 mm

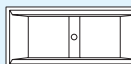

700076
● ● □ 1



700081
8788 □ 2



700081
8783 □ 2

2190 x 1190 mm

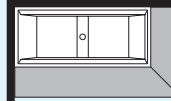

700081
8805 □ 4

2190 x 1190 mm

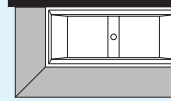

700081
8803 □ 4



700081
8778 □ 5

2190 x 1190 mm

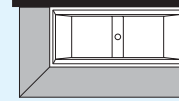

700081
8799 □ 9

2100 x 900 mm

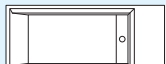

700077
● □ 1



700082
8789 □ 3



700082
8784 □ 3



700082
8779 □ 6
8810 L, # 8811 R □ 7
8812 L, # 8813 R □ 8

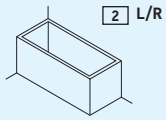

□ 2 L/R

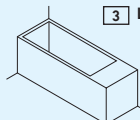

□ 3 L/R

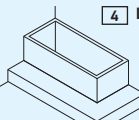

□ 4 L/R

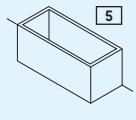

□ 5

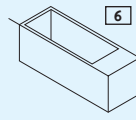

□ 6

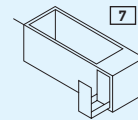

□ 7 L/R

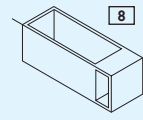

□ 8 L/R

1 □ Badewanne Einbauversion, Bathtub Built-In, Vasca da bagno, versione da incasso, Baignoire à encastrer, Bad inbouwversie, Bañera accesorios de instalación no incluidos

800 x 800 mm



720043 □ 16

800 x 1000 mm



720044 □ 16

800 x 1200 mm



720045 □ 16



720043 □ 17
8870



720044 □ 17
8871



720045 □ 17
8872

900 x 900 mm



720046 □ 16

900 x 1000 mm



720047 □ 16

900 x 1400 mm



720048 □ 16

900 x 1800 mm

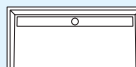

720049 □ 16



720046 □ 17
8873



720047 □ 17
8874



720048 □ 17
8875



720049 □ 17
8876

1000 x 1000 mm



720050 □ 16

1000 x 1200 mm



720051 □ 16



720050 □ 17
8877



720051 □ 17
8878

16 □ Duschwanne Einbauversion, Shower Tray Built-In, Piatto doccia, versione da incasso, Receveur de douche à encastrer, Douchebak Inbouwversie, Plato de ducha

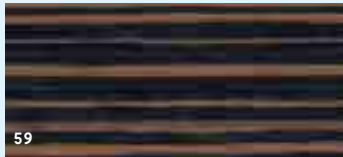

59

Ebenholz, Ebony,
Ebano, Bois d' ébène,
Ebenhout, Ébano

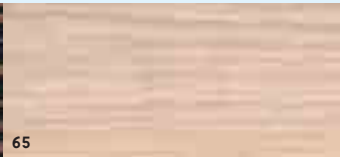

65

Eiche gekalkt, Limed oak,
Rovere sbiancato, Chêne chaulé,
Eiken gekalkt, Roble blanqueada



66

Kirschbaum, Cherry,
Ciliegio, Cerisier,
Kersen, Cerezo



67

Palisander, Rosewood,
Palissandro, Palissandre,
Palissander, Palisandro

2090 x 1140 mm

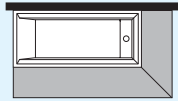

700080
8800 9

2090 x 1140 mm

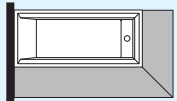

700080
8806 10

2090 x 1140 mm

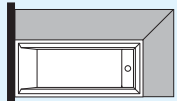

700080
8808 11



700080
8772 11

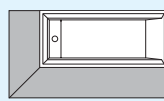

700080
8790 15

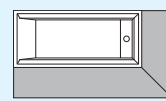

700080
8792 15

2190 x 1190 mm

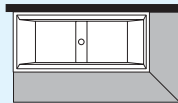

700081
8801 9

2190 x 1190 mm

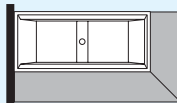

700081
8807 10

2190 x 1190 mm

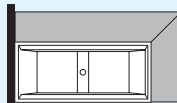

700081
8809 10

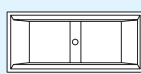

700081
8773 11

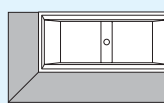

700081
8791 15

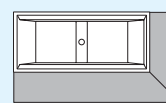

700081
8793 15



700082
8774 12
8794 L, # 8795 R 13
8796 L, # 8797 R 14

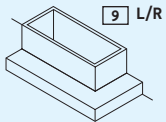

9 L/R

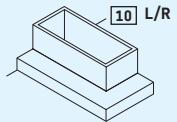

10 L/R

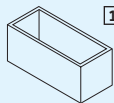

11

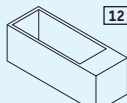

12

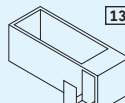

13 L/R

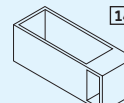

14 L/R

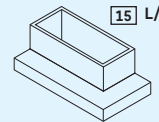

15 L/R

2 - 15 Badewanne mit Möbelverkleidung, Bathtub with Furniture Panel, Vasca da bagno con pannello di rivestimento in legno, Baignoire avec habillage façon meuble, Bad met panelen, Bañera con revestimiento

L/R = Links/Rechts
Left/Right
sinistra/destra
à gauche/à droite
Links/Rechts
izquierda/devecha



720043 17
8860



720044 17
8861

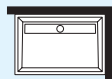

720045 17
8862



720043 17
8880



720044 17
8881

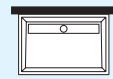

720045 17
8882



720046 17
8863



720047 17
8864



720048 17
8865

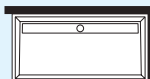

720049 17
8866



720046 17
8883



720047 17
8884

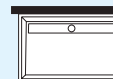

720048 17
8885

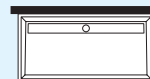

720049 17
8886



720050 17
8867



720051 17
8868



720050 17
8887



720051 17
8888

17 Duschwanne mit Möbelverkleidung, Shower Tray with Furniture Panel, Piatto doccia, con pannello di rivestimento in legno, Receveur avec habillage façon meuble, Douchebak met panelen, Plato de ducha con revestimiento

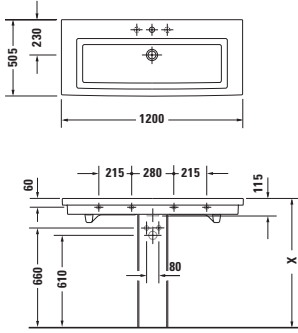
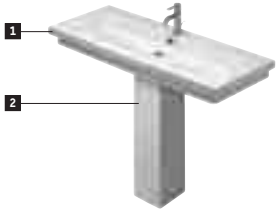

- 1 # 049112..00 ●
- # 049112..30 ●●●
- 2 # 0863190000

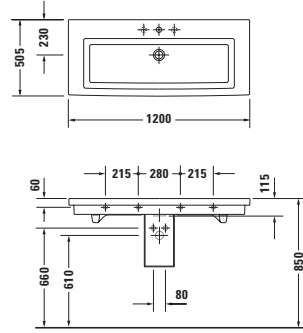

- 1 # 049112..00 ●
- # 049112..30 ●●●
- 2 # 0857140000

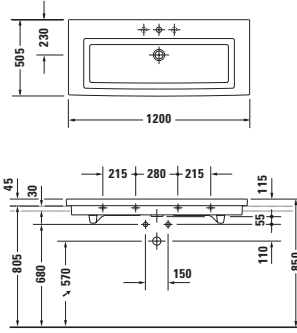

- # 049112..27* ●
- # 049112..25* ●●●
- # 8564

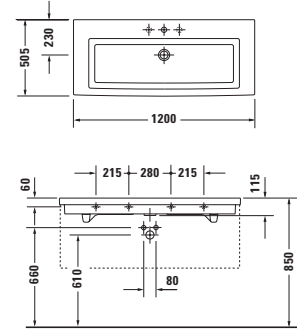

→ # 6448

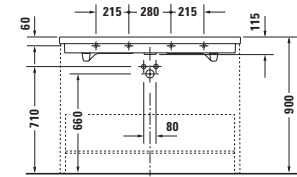

→ # 6458

- # 049112..00 ●
- # 049112..30 ●●●
- # 6408, 6443, 6448, 6458

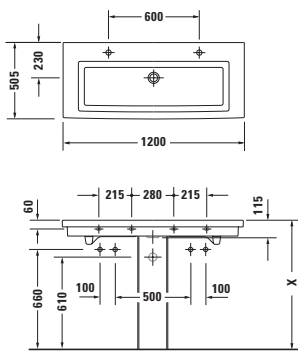
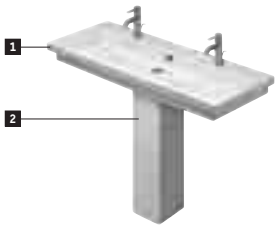

- 1 # 049112..24 ● ●
- 2 # 0863190000

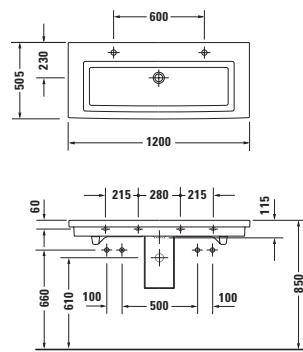
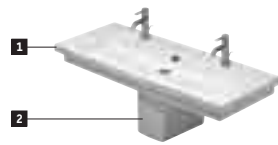

- 1 # 049112..24 ● ●
- 2 # 0857140000

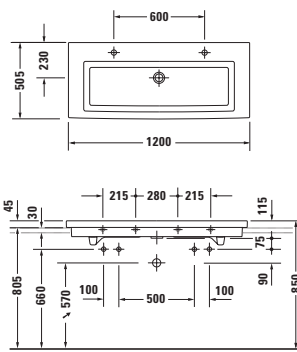

- # 049112..26* ● ●
- # 8564

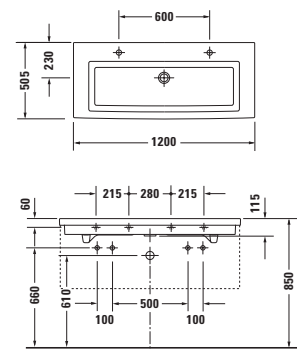

→ # 6448

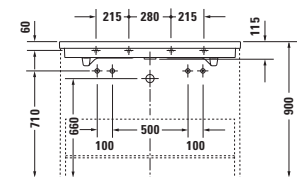

→ # 6458

- # 049112..24 ● ●
- # 6408, 6443, 6448, 6458

* Waschtische geschliffen in Kombination mit Konsolen. Washbasin grinded in combination with consoles. Dessous lissé, pour combinaison avec consoles. Wastafel geslepen in combinatie met consoles. I lavabi rettificati sono adatti all'installazione su mobili o consolle attrezzate. Lavabo rectificado en combinación con encimeras

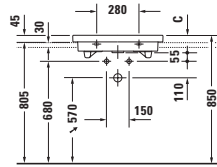
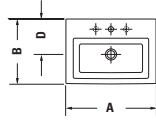
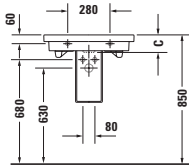
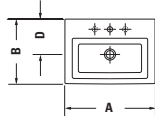
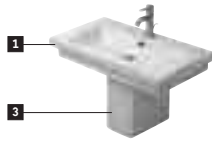
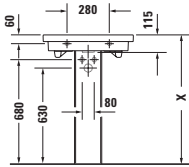
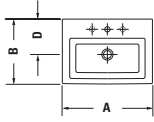
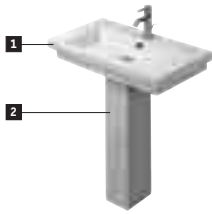

049180 → 8563, # 049170 → 8562

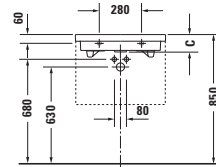
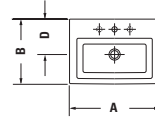

049180 → 6447, # 049160 → 6446

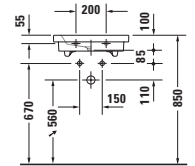
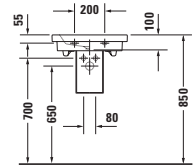
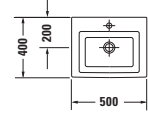
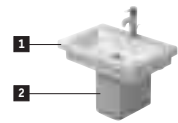

049180 → 6457, # 049160 → 6456

	A	B	C	D
800 mm	800	500	115	230
700 mm	700	460	115	235
600 mm	600	430	115	230

- | | | | | | |
|-------------------------|-------------------------|-------------------------|-------------------|----------------------------|-------------------------|
| 1 # 049180..00 ● | 2 → # 0863190000 | 3 → # 0857140000 | # 049180..27* ● | # 049180..00 ● | 1 # 0790500000 ● |
| # 049180..30 ●● | → # 0863190000 | → # 0857140000 | # 049180..25* ●●● | # 049180..30 ●●● | 2 # 0857130000 |
| # 049170..00 ●● | → # 0863180000 | → # 0857160000 | → # 8563 | → # 6407, 6442, 6447, 6457 | |
| # 049170..30 ●●● | → # 0863180000 | → # 0857160000 | # 049170..27* ● | # 049160..00 ● | |
| # 049160..00 ●● | → # 0863180000 | → # 0857160000 | # 049170..25* ●●● | # 049160..30 ●●● | |
| # 049160..30 ●●● | → # 0863180000 | → # 0857160000 | → # 8562 | → # 6406, 6441, 6446, 6456 | |

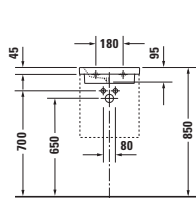
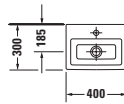
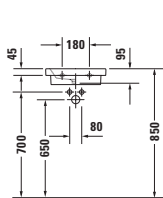
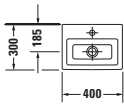

→ # 6445 L/R

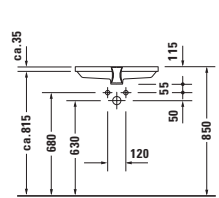
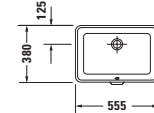
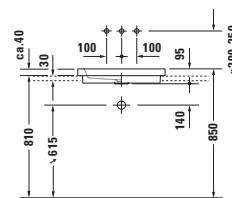
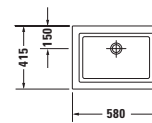
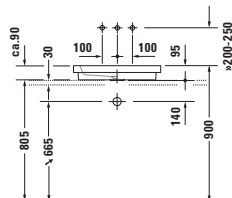
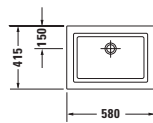

0790400000 ●

0790400000 ●
→ # 6405, 6440, 6445 L/R, 6455 L/R

031758..00 ⊗ ✕
→ # 8561, 8981

031758..29 ⊗ ✕
→ # 8560, 8981

031653..00 ⊗ ✕



.. = 00 - Weiß Alpin. White Alpin.
Blanc Alpin. Wit Alpin.
Bianco Alpin. Bianco Alpin



.. = 66 - Edelstahl matt. Matt Stainless Steel.
Inox mat. Edelstahl mat. Acciaio satinato.
Acero inoxidable mate

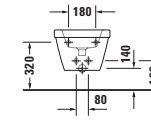
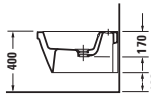
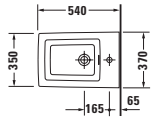

2235150000 ●

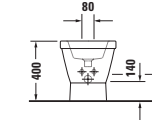
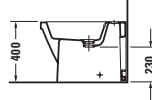
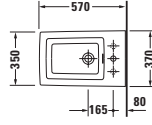

0136100000 ●
0136100030 ●●●

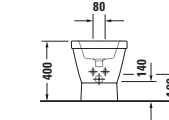
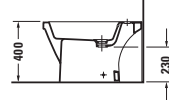
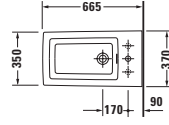

0137100000 ●
0137100030 ●●●

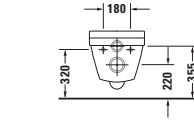
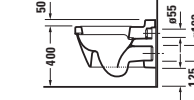
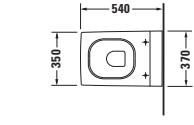

1 # 0068990000
2 # 2205090000 ▲ ◻ ◻

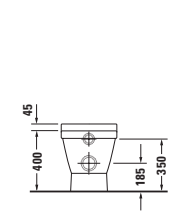
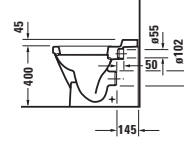
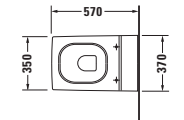

1 # 0068990000
2 # 0110090000 ▲ ◻ ◻

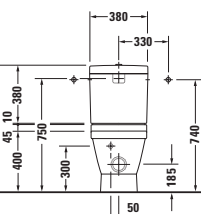
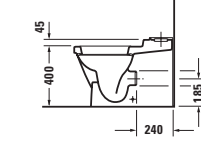
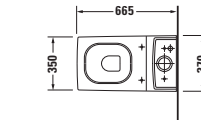

1 # 0068990000
2 # 2106090000 ▲ ◻ ◻

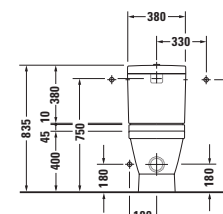
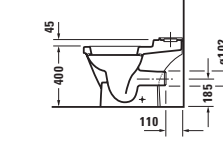
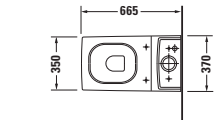

1 # 0068990000
2 # 2107090000 ▲ ◻ ◻
3 # 0876000005 ▶ ◻ ◻ ◻ ◻
0876100005 ▶ ◻ ◻ ◻ ◻

- X Genaueres Maß durch Unterstellen der Säule ermitteln. To determine height please set washbasin on pedestal. Définir les dimensions exactes par rapport au positionnement de la colonne. Precizie maten t.o.v. de plaatsing van de zuil aangeven. Determinare l'altezza esatta posizionando la colonna sotto il lavabo.
- La altura de fijación se determina poniendo el pedestal por debajo del lavabo
- Bei Verwendung des Siphon # 0050361000. With usage of design siphon # 0050361000. Pour l'utilisation du siphon design # 0050361000. Utilizando el sifón de diseño # 0050361000
- Als de design sifon # 0050361000 gebruikt wordt. Se si utilizza il sifone # 0050361000.
- Maß abhängig vom Unterbau (Unterbau 50 mm nach oben verstellbar). Dependent on vanity unit (Vanity unit can be raised by 50 mm). Cote dépend du meuble sous-lavabo (Meuble sous-lavabo 50 mm réglable en hauteur). De maat is afhankelijk van de onderbouw (Onderbouw 50 mm naar boven verstelbaar). La dimensione dipende dalla base sottolavabo (base sottolavabo regolabile di 50 mm verso l'alto). Medida depende del mueble lavabo (Mueble ajustable en altura, 50 mm hacia arriba).
- Abhängig vom Auslauf. Depending on outlet. Dépend de l'évacuation. Afhankelijk van de afloop. A seconda dello scarico. Depende del desagüe
- ⊗ Kein Hahnloch (glatt). Without tap hole. Sans trou. Zonder kraangat. Nessun foro. Sin agujero para grifería
- Hahnloch durchgestochen. Tap hole punched. Trou percé. Kraangat doorgestoken. Monoforo. 1 agujero para grifería hecho
- 3 Hahnlöcher durchgestochen. 3 tap holes punched. 3 trous percés. 3 Kraangaten doorgestoken. 3 fori. 3 agujeros para grifería hechos
- ▲ Montage von oben. Installation from above. Montage par-dessus. Montage van boven. Installazione dall'alto. Montaje desde arriba
- ◻ Montage von unten. Installation from below. Montage par-dessous. Montage van onder. Installazione dal basso. Montaje desde abajo
- ◻ Abgang vertikal. Vertical outlet. Sortie verticale. Afvoer verticaal. Scarico verticale. Desagüe vertical
- ◻ Abgang horizontal. Horizontal outlet. Sortie horizontale. Afvoer horizontaal. Scarico orizzontale. Desagüe horizontal
- ▲ Steht für alle WCs und Spülkästen, die mit 6 Liter Spülwassermenge auskommen. Economical 6-liter flush. Ce symbole accompagne les réservoirs et cuvettes permettant un rinçage économique avec seulement 6 litres d'eau. Staat voor alle wc's en reservoirs, die met 6 ltr. kunnen spoelen. Per vasi e cassette con sciacquo a 6 litri. Cisterna e inodoro de consumo económico de 6 litros
- ▶ Anschluss links. Side supply, left. Alimentation latérale à gauche. Aansluiting links. Allacciamento a sinistra. Cisterna, alimentación lateral, izquierda
- ◻ Anschluss rechts. Side supply, right. Alimentation latérale à droite. Aansluiting rechts. Allacciamento a destra. Cisterna, alimentación lateral, derecha
- ◻ Anschluss mitte. Back supply. Alimentation arrière. Aansluiting midden. Allacciamento centrale posteriore. Cisterna alimentación posterior
- ◻ Anschluss unten links. Bottom left supply. Alimentation dessous gauche. Aansluiting links onder. Allacciamento in basso a sinistra. Cisterna alimentación inferior izquierda

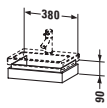

6405
 ↔ 380 mm, 7 290 mm
 → # 0790400000, 400 mm

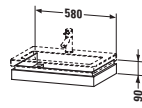

6406
 ↔ 580 mm, 7 420 mm
 → # 0491600000, 600 mm
 → # 0491600030, 600 mm

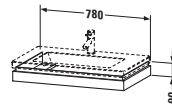

6407
 ↔ 780 mm, 7 490 mm
 → # 0491800000, 800 mm
 → # 0491800030, 800 mm

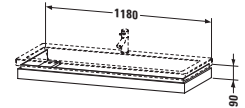

6408
 ↔ 1180 mm, 7 490 mm
 → # 0491120000, 1200 mm
 → # 0491120030, 1200 mm
 → # 0491120024, 1200 mm

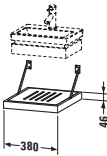

6440
 ↔ 380 mm, 7 270 mm
 → # 6405

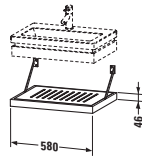

6441
 ↔ 580 mm, 7 400 mm
 → # 6406

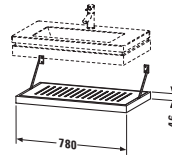

6442
 ↔ 780 mm, 7 440 mm
 → # 6407

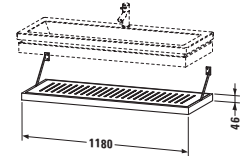

6443
 ↔ 1180 mm, 7 440 mm
 → # 6408

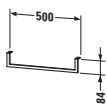

9985
 ↔ 500 mm
 Handtuchhalter. Towel rail.
 Porte-serviettes. Handdoekhouder.
 Portasciugamani. Toallero
 → # 6406-6408

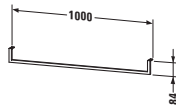

9986
 ↔ 1000 mm
 Handtuchhalter. Towel rail.
 Porte-serviettes. Handdoekhouder.
 Portasciugamani. Toallero
 → # 6408

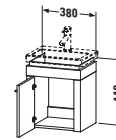

6445 L/R
 ↔ 380 mm, 7 290 mm
 → # 0790400000, 400 mm

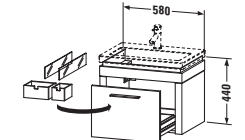

6446
 ↔ 580 mm, 7 420 mm
 → # 0491600000, 600 mm
 → # 0491600030, 600 mm

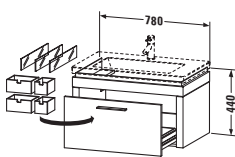

6447
 ↔ 780 mm, 7 490 mm
 → # 0491800000, 800 mm
 → # 0491800030, 800 mm

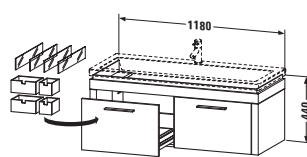

6448
 ↔ 1180 mm, 7 490 mm
 → # 0491120000, 1200 mm
 → # 0491120030, 1200 mm
 → # 0491120024, 1200 mm

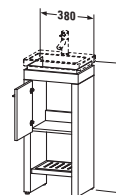

6455 L/R
 ↔ 380 mm, 7 290 mm
 → # 0790400000, 400 mm

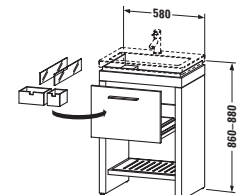

6456
 ↔ 580 mm, 7 420 mm
 → # 0491600000, 600 mm
 → # 0491600030, 600 mm

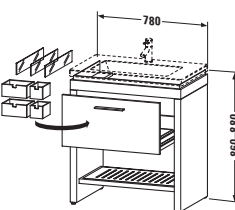

6457
 ↔ 780 mm, 7 490 mm
 → # 0491800000, 800 mm
 → # 0491800030, 800 mm

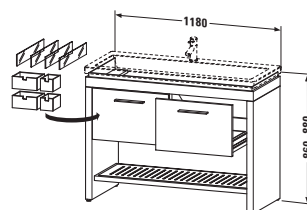

6458
 ↔ 1180 mm, 7 490 mm
 → # 0491120000, 1200 mm
 → # 0491120030, 1200 mm
 → # 0491120024, 1200 mm

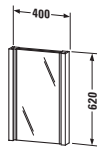

9645 \varnothing 2 x 14 W
 \leftrightarrow 400 mm, \nearrow 72 mm

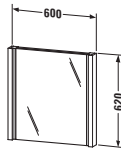

9646 \varnothing 2 x 14 W
 \leftrightarrow 600 mm, \nearrow 72 mm

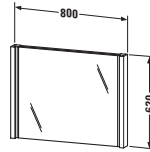

9647 \varnothing 2 x 14 W
 \leftrightarrow 800 mm, \nearrow 72 mm

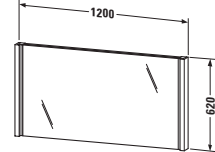

9648 \varnothing 2 x 14 W
 \leftrightarrow 1200 mm, \nearrow 72 mm

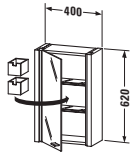

9650 L/R \varnothing 2 x 14 W
 \leftrightarrow 400 mm, \nearrow 200 mm

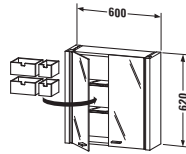

9651 \varnothing 2 x 14 W
 \leftrightarrow 600 mm, \nearrow 200 mm

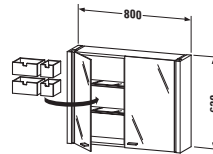

9652 \varnothing 2 x 14 W
 \leftrightarrow 800 mm, \nearrow 200 mm

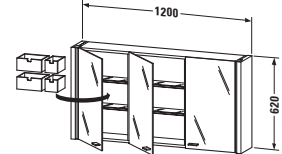

9653 \varnothing 2 x 14 W
 \leftrightarrow 1200 mm, \nearrow 200 mm

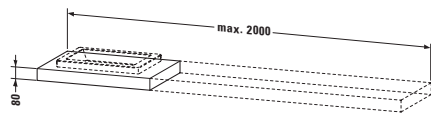

8560 2nd floor # 031758 580 mm
 # 8561 2nd floor # 031758 580 mm
 # 8562 2nd floor # 049170 700 mm
 # 8563 2nd floor # 049180 800 mm
 # 8564 2nd floor # 049112 1200 mm

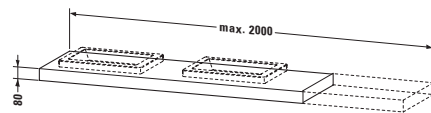

8580 2nd floor # 031758 580 mm
 # 8581 2nd floor # 031758 580 mm
 # 8582 2nd floor # 049170 700 mm

Variable Konsole. Variable console. Plan de toilette modulaire. Console variable. Consolle attrezzate di larghezza variabile. Encimera variable \leftrightarrow max. 2700 mm

Individuelle Lösungen mit beliebig breiten Konsolen und beliebiger Anordnung der Unterschränke, Konsolenträger (Skizze beilegen).
 Individual solutions with variably wide consoles and variable arrangement of vanity units, console supports (enclose sketch).
 Solutions personnalisées avec diverses largeurs de plans et équipement de meubles bas, consoles sur demande (produire un plan).
 Individuele oplossingen, breedte console op wens en naar keuze uitbreiding met onderbouwkast, consoledrager (schets geven bij bestelling).
 Soluzioni individuali con consolle attrezzate della larghezza desiderata e libera disposizione delle basi sospese, staffe di sostegno (allegare disegno).
 Soluciones individualizadas con encimeras variables y colocación individualizada de los muebles bajo encimera, soporte toallero (adjuntar dibujo de distribución)

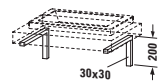

9927
 \nearrow 420 mm
 Konsolenträger-Winkel (verdeckt).
 Console support bracket (hidden).
 Pour montage des consoles
 modulaires console-angle (cachée).
 Voor onderbouwen van de variabele
 consoles Consoledrager-hoek (verdekt).
 Staffa di sostegno.
 Soporte encimera

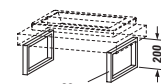

9928
 \nearrow 480 mm
 Konsolenträger - Handtuchhalter.
 Console support towel rail.
 Support console (porte-serviettes).
 Consoledrager-handdoekhouder.
 Staffa di sostegno - portasciugamani.
 Soporte encimera - toallero

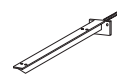

9926
 \nearrow 420 mm

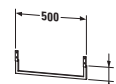

9983
 \leftrightarrow 500 mm
 Handtuchhalter. Towel rail.
 Porte-serviettes. Handdoekhouder.
 Portasciugamani. Toallero
 \rightarrow # 8560-8564

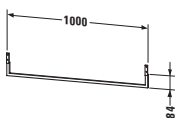

9984
 \leftrightarrow 1000 mm
 Handtuchhalter. Towel rail.
 Porte-serviettes. Handdoekhouder.
 Portasciugamani. Toallero
 \rightarrow # 8560-8564

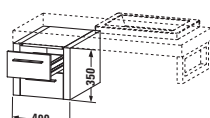

9275
 \leftrightarrow 400 mm, \nearrow 550 mm

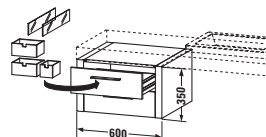

9276
 \leftrightarrow 600 mm, \nearrow 550 mm

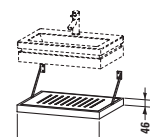

6441
 \leftrightarrow 580 mm, \nearrow 440 mm

2nd floor

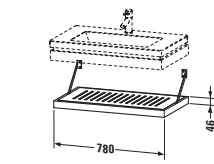

6442
↔ 780 mm, ↗ 440 mm

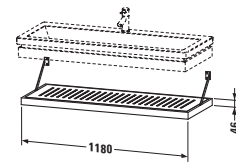

6443
↔ 1180 mm, ↗ 440 mm

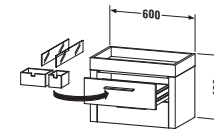

9266
↔ 600 mm, ↗ 360 mm

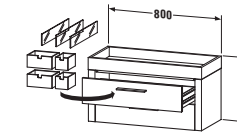

9267
↔ 800 mm, ↗ 360 mm

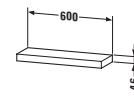

9405
↔ 600 mm, ↗ 200 mm

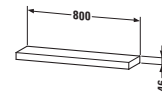

9406
↔ 800 mm, ↗ 200 mm

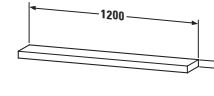

9407
↔ 1200 mm, ↗ 200 mm

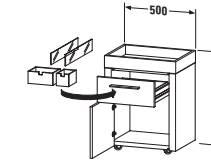

9272
↔ 500 mm, ↗ 360 mm

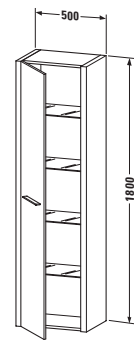

9156 L/R
↔ 500 mm, ↗ 360 mm

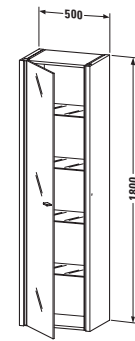

9157 L/R $\text{\textcircled{W}}$ 4 x 21 W
↔ 500 mm, ↗ 360 mm



9913
↔ 160 mm, ↗ 120 mm



9914
↔ 80 mm, ↗ 120 mm

9993 ↗ 300 mm
↔ 600/800 mm, ↗ 270 mm
Sideboard. Sideboard.
Élément mural. Sideboard.
Mensola attrezzata. Armario lateral
↔ 500 mm, ↗ 270 mm
Rollcontainer. Mobile storage.
Container à roulettes. Rolcontainer.
Base su ruote. Contenedor con ruedas

Glasplatte Schütten-Einteilung für Schubkasten.
Box drawer-divider.
Séparation pour compartiment.
Schuiflade-indeling.
Separatori in vetro.
Separadores para cajones de distribución

9994 ↗ 450 mm
↔ 600 mm, ↗ 420 mm
Unterschrank Konsole.
Floor cabinet for consoles.
Onderkast voor consoles.
Meuble bas pour plan de toilette.
Base sospesa per consolle attrezzata.
Mueble bajo encimera

Glasplatte Schütten-Einteilung für Schubkasten.
Box drawer-divider.
Séparation pour compartiment.
Schuiflade-indeling.
Separatori in vetro.
Separadores para cajones de distribución

9996 ↗ 300 mm
↔ 600 mm, ↗ 270 mm
Waschtischunterbau. Vanity unit.
Meuble sous-lavabo. Wastafelonderbouw.
Base sottolavabo. Mueble lavabo

Glasplatte Schütten-Einteilung für Auszug.
Box drawer pull out shelf with divider.
Compartiments pour tiroirs et casiers coulissants.
Schuiflade-indeling.
Separatori in vetro (per elementi estraibili delle consolle attrezzate).
Separadores para cajones de distribución para cajones correderos

9997 ↗ 350 mm
↔ 800/1200 mm, ↗ 320 mm
Waschtischunterbau. Vanity unit.
Meuble sous-lavabo. Wastafelonderbouw.
Base sottolavabo. Mueble lavabo

Glasplatte Schütten-Einteilung für Auszug.
Box drawer pull out shelf with divider.
Compartiments pour tiroirs et casiers coulissants.
Schuiflade-indeling.
Separatori in vetro (per elementi estraibili delle consolle attrezzate).
Separadores para cajones de distribución para cajones correderos

↗ Tiefe. Depth. Profondeur. Diepte. Profondità. Profundidad
↔ Breite. Width. Largeur. Breedte. Larghezza. Anchura
L/R Links/Rechts. Left/Right. Gauche/Droite. Rechts/Links. A sinistra/A destra. Izquierda/Derecha
 $\text{\textcircled{W}}$ Mit Beleuchtung. With lighting. Avec éclairage. Met binnenverlichting. Con illuminazione. Con iluminación
Leuchtstoffröhre. Fluorescent tubes. Tubes fluorescents. TL-lampen. Lampada al neon. Tubo fluorescente

Nähere Informationen zu 2nd floor Bade- und Duschwannen sowie Whirl- und Wellness-Systeme erhalten Sie auf Anfrage.
Further information on 2nd floor bathtubs and shower trays, whirl and wellbeing systems on request.
Davantage de renseignements concernant les baignoires, les receveurs de douche 2nd floor et les systèmes balnéos sur demande.
Nadere informatie t.b.v. 2nd Floor ligbaden, douchebakken, whirl- en wellnessystemen op aanvraag.
Informazioni più dettagliate per vasche da bagno e piatti doccia 2nd floor e pure su i sistemi d'idromassaggio si possono ottenere su richiesta.
Tenemos a su disposición más información referente a bañeras y platos de ducha, así como sistemas de hidromasaje de la serie 2nd floor sobre petición

Best.-Nr. 001244/05.01.06.5.1 · Printed in Germany
Technische Verbesserungen und optische Veränderungen an den abgebildeten Produkten behalten wir uns vor.
We reserve the right to make technical improvements and enhance the appearance of the products shown.
Nous nous réservons de droit d'apporter des améliorations techniques et de modifier l'apparence visuelle des produits présentés.
Technische verbeteringen en optische wijzigingen ten opzichte van de afgebeelde producten voorbehouden.
Con riserva di apportare modifiche tecniche.
Nos reservamos el derecho de realizar modificaciones técnicas y de aspecto de los productos representados