





PREMASS®

LA NUOVA TRADIZIONE

THE NEW TRADITION

DIE NEUE TRADITION

LA NOUVELLE TRADITION

AU PARQUETS®

100% SOLID WOOD

100% MASSIVHOLZ

PREMASS®

Elementi prefiniti di legno massiccio con sistema di assemblaggio per pavimentazioni di legno – UNI EN 13228

Solid prefinished wood flooring elements with an interlocking system - EN 13228

Massivholz-Parkettstäbe mit einem Verbindungssystem für Holzfußböden - DIN EN 13228

Éléments de parquet en bois massif avec un système de guidage pour planchers en bois - NF EN 13228



PreMass Thermo Frassino 215 °C

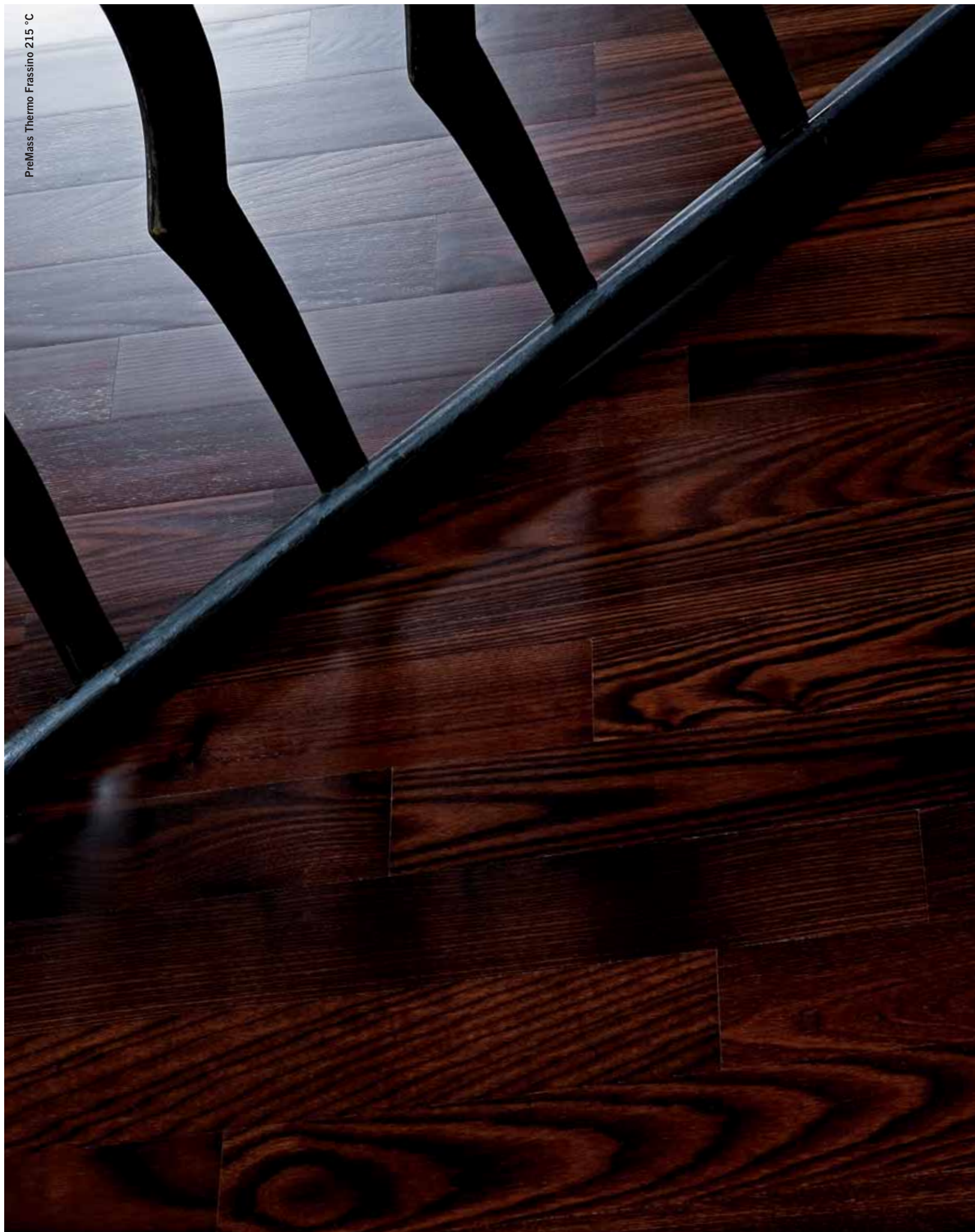



PREMASS®

LA NUOVA TRADIZIONE

PreMass è il primo parquet prefinito in legno massello introdotto nel mercato. Grazie alla sua accurata verniciatura, presenta l'aspetto di un tradizionale parquet in massello ma offre - rispetto a questo - un'estrema praticità di messa in opera che non richiede ulteriori finiture in posa. Queste le caratteristiche del pavimento in legno nobile prefinito **PreMass**: un prodotto di eccellenza nella gamma ALI che segna l'evoluzione di una grande e intramontabile tradizione.

La linea **PreMass**, spessore 10 millimetri di cui 5 sopra il maschio, propone anche le versioni Living, Trend, Linear, Cover, Color, Intarsi e Cornici.

THE NEW TRADITION

PreMass is the first prefinished solid wood parquet to be placed on the market. Varnished to the highest standards, it looks like a traditional solid wood parquet, but is actually extremely simple to install and does not require any further finishing after laying. These are the characteristics of the **PreMass** prefinished hardwood floor: an outstanding product in the ALI range, marking the evolution of a great, unending tradition.

The **PreMass** line, 10 millimetres thick, 5 mm of which above the tongue, also includes the Living, Trend, Linear, Cover, Color, Intarsi and Cornici versions.

DIE NEUE TRADITION

PreMass ist das erste Massivholzfertigparkett, das auf dem Markt eingeführt wurde. Beim Massivholzfertigparkett **PreMass** entfällt die Endbehandlung auf der Baustelle. Es wird im Werk geschliffen und lackiert. Eine vierseitige Nut-Feder-Verbindung fügt diesen robusten Stab bei der Klebung zu einer vollkommen ebenen Fläche zusammen.

Die Produktlinie **PreMass**, 10 Millimeter Stärke, davon 5 mm Nuttschicht über der Feder, wird auch in den Versionen Living, Trend, Linear, Cover, Color, Intarsi und Cornici angeboten.

LA NOUVELLE TRADITION

PreMass est le premier parquet vernis-usine en bois massif introduit sur le marché. Grâce à son vernissage soigné, il a l'aspect d'un parquet traditionnel en bois massif mais il offre, contrairement à ce dernier – une extrême facilité de pose qui ne requiert par de finitions supplémentaires. Voici les caractéristiques du pavage en bois massif noble vernis-usine **PreMass** : un produit d'excellence dans la gamme ALI qui marque l'évolution d'une grande tradition éternelle.

La ligne **PreMass**, épaisseur 10 millimètres dont 5 au-dessus du tenon, propose également les versions Living, Trend, Linear, Cover, Color, Intarsi et Cornici.



PreMass Afromosia

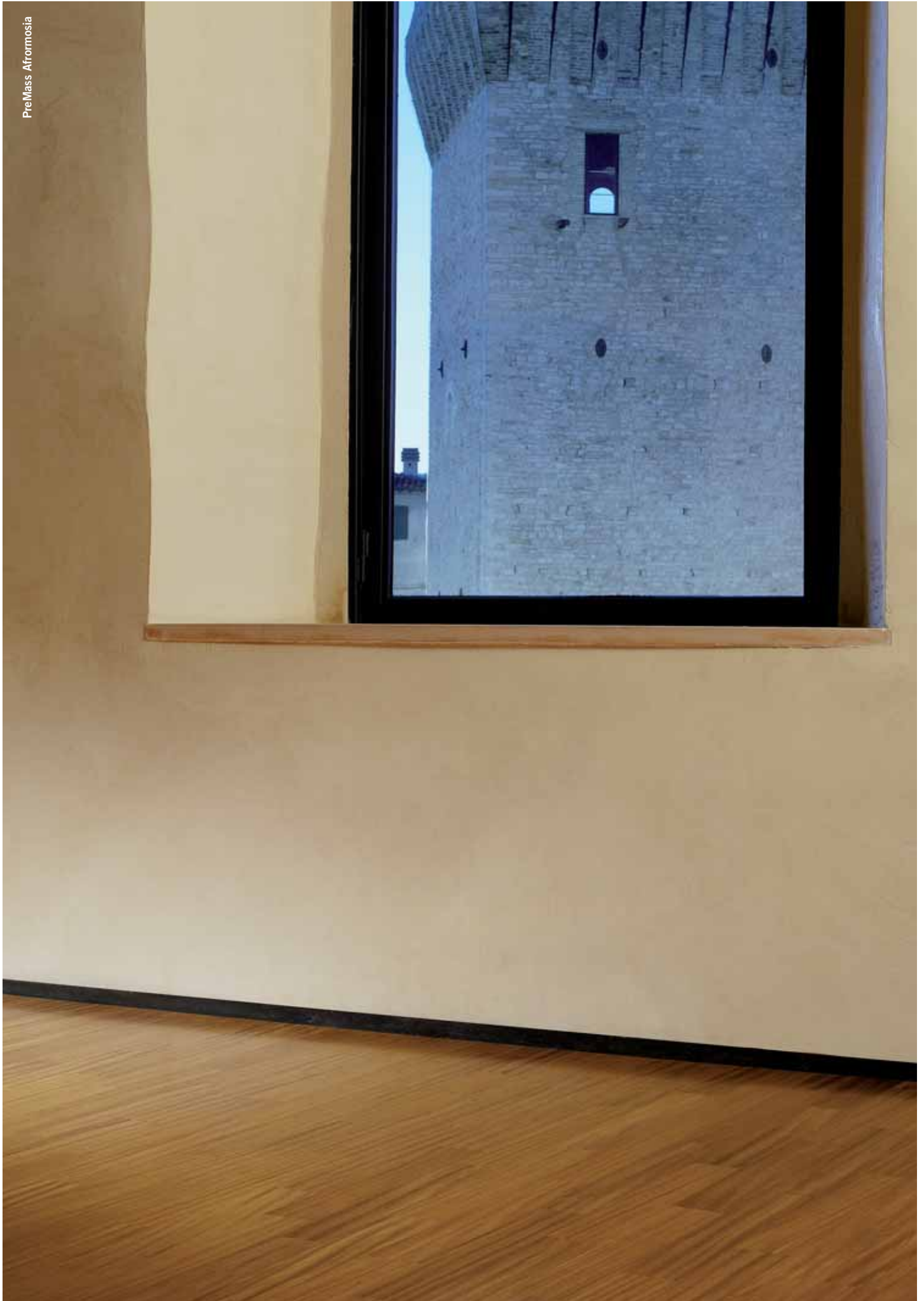

PreMass Thermo Betulla 190 °C



PREMASS®

Elementi prefiniti di legno massiccio con sistema di assemblaggio per pavimentazioni di legno - UNI EN 13228

Solid prefinished wood flooring elements with an interlocking system - EN 13228

Massivholz-Parkettstäbe mit einem Verbindungssystem für Holzfußböden - DIN EN 13228

Éléments de parquet en bois massif avec un système de guidage pour planchers en bois - NF EN 13228

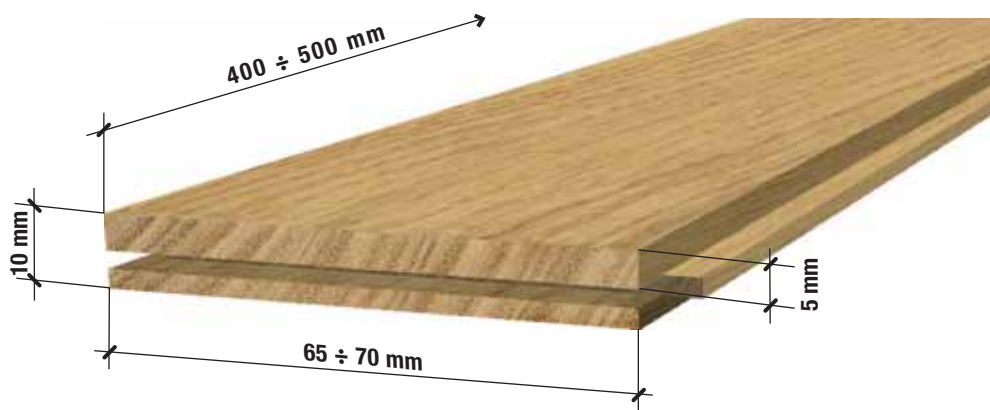

PREMASS®

L



F



ACERO



AFRORMOSIA



CABREUVA INCIENSO



CILIEGIO EUROPA



DOUSSIÉ



IROKO



JATOBÁ



MERBAU







MUTENYE



ROVERE

PREMASS®

L  

F   

 TEAK

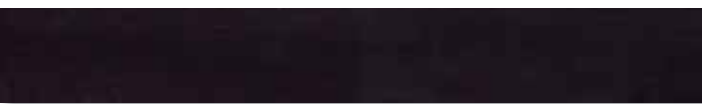

 WENGÉ

 THERMO BETULLA 190 °C*

 THERMO FRASSINO 190 °C*

 THERMO FRASSINO 215 °C*

PREMASS® LIVING

L   

F 

 DOUSSIÉ

 IROKO



 ROVERE

 TEAK

 THERMO FRASSINO 190 °C*

* IT - Prodotto sottoposto a trattamento termico / EN - Heat-treated product / DE - Produkt wurde wärmebehandelt / FR - Produit soumis à un traitement thermique

PREMASS® TREND

L  

F 

 DOUSSIÉ



 IROKO

 ROVERE

 TEAK

PREMASS® COVER

L  

C  F 

 ROVERE WHITE

 ROVERE OLD

 ROVERE BROWN

PREMASS® CORNICI

L



F



- IT Listello ottenuto per accostamento di elementi in legno massello monostrato di differenti specie legnose.
 EN Strip consisting of a combination of single-layer solid strips of different types of wood.
 DE Holz gefertigt aus dem Verbund mehrerer einschichtiger Massivholzelemente verschiedener Holzarten
 FR Lame obtenue par association d'éléments en bois massif monocouche de différentes espèces ligneuses.

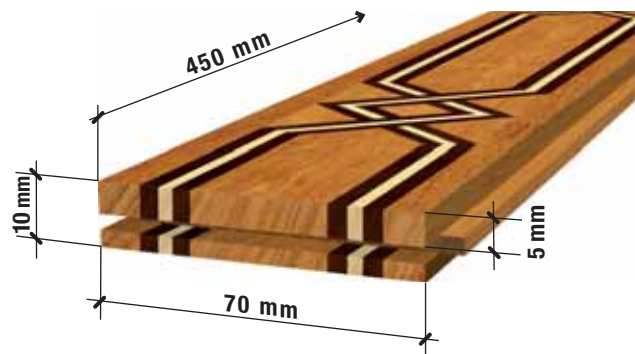

K0 CAMMEO



K1 ANELLI



K2 BINARIO



K3 GRECA



K4 DIAMANTI



K5 INTRECCIO



K6 STELLE



K7 TARSIA



K8 TESSERE



K9 GEMME

PREMASS® LINEAR

L



F



- IT Listello ricavato dall'assemblaggio di più moduli lineari di legno massello monostrato della medesima specie legnosa.
 EN Strip consisting of a combination of single-layer solid strips of the same type of wood.
 DE Holzstab gefertigt aus dem Verbund mehrerer einschichtiger Massivholzmodule derselben Holzart
 FR Lame obtenue par l'assemblage de plusieurs modules linéaires en bois massif monocouche de la même espèce ligneuse.

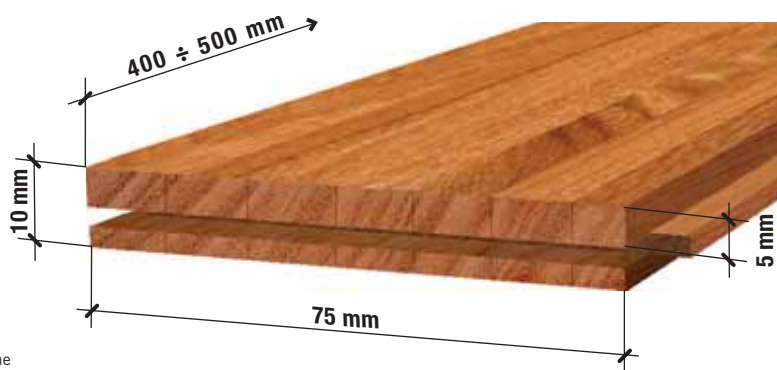

AFRORMOSIA



DOUSSIÉ



IROKO



JATOBÁ

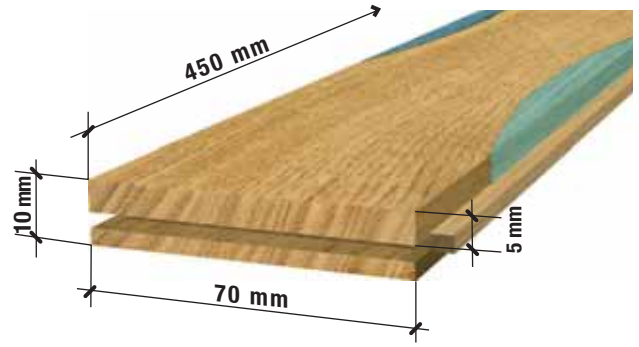

IV VISTO



IC COPPIA



IF FUSILLO



IL VOLTE



IE ENIGMA



IB BACCHE



13 COROLLE 3



14 COROLLE 4



17 COROLLE 7



IP PROFILO



IO ONDINE

IT Listello ricavato da un legno massello monostato intarsiato con uno o più elementi ricavati da listelli di PreMass Color
 EN Strip made from a single layer of solid wood inlaid with one or more inlays made from PreMass Color strips
 DE Leiste mit Intarsien aus einschichtigen Massivholz mit einem oder mehreren Elementen aus PreMass Color-Holzstäben
 FR Lame obtenue par un bois massif monocouche marqueté avec un ou plusieurs éléments extraits des lames de PreMass Color

**BASI INTARSI STANDARD
 STANDARD BASES INTARSI
 INTARSIEN BASISHÖLZER
 BASES STANDARD INTARSI**



	VISTO	COPPIA	FUSILLO	VOLTE	ENIGMA	BACCHE	COROLLE 7	COROLLE 3, 4, 7	PROFILO	ONDINE
BIANCO LATTE										
GIALLO PRIMULA										
ROSA PESCA										
GRIGIO SASSO										
VERDE LAGO										
AZZURRO MARINA										
BLU PETROLIO										
VERDE ALLORO										
NERO LAVAGNA										
ROSSO LAMPONE										

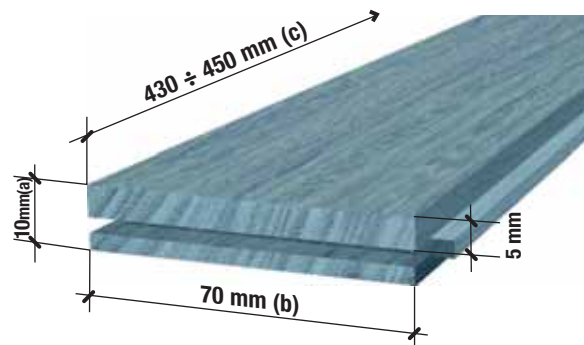

IT Listello ricavato da legno ricomposto ottenuto dall'unione di strati in legno massello colorati a tutto spessore
 EN Composite wood strip produced by combining layers of through-coloured solid wood
 DE Leiste aus dem Verbund einzelner massiver Holzschichten vollständig durchgefärbt
 FR Lame extraite de bois recomposé obtenu par l'union de couches en bois massif colorées sur toute l'épaisseur

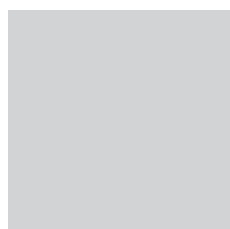

TASELLO
 (a) = 10 mm
 (b) = 70 mm
 (c) = 70 mm



1/2 TASELLO
 (a) = 10 mm
 (b) = 70 mm
 (c) = 35 mm

C2 BIANCO LATTE	TASELLO	1/2 TASELLO
C4 GIALLO PRIMULA	TASELLO	1/2 TASELLO
C5 ROSA PESCA	TASELLO	1/2 TASELLO
C8 GRIGIO SASSO	TASELLO	1/2 TASELLO
C7 VERDE LAGO	TASELLO	1/2 TASELLO
C6 AZZURRO MARINA	TASELLO	1/2 TASELLO
C9 BLU PETROLIO	TASELLO	1/2 TASELLO
C3 VERDE ALLORO	TASELLO	1/2 TASELLO
C0 NERO LAVAGNA	TASELLO	1/2 TASELLO
C1 ROSSO LAMPONE	TASELLO	1/2 TASELLO

**CALIBRATO**

I singoli elementi in legno vengono lavorati con una precisione al centesimo di millimetro sullo spessore; questa lavorazione consente di ottenere spessori uniformi per ogni linea di prodotto, contribuendo in modo fondamentale alla realizzazione di un pavimento planare, privo di dislivello tra i diversi elementi in legno.

**SPAZZOLATO**

Processo di lavorazione attraverso il quale apposite spazzole vengono energicamente applicate sulla faccia dell'elemento in legno; in questo modo le zone più resistenti all'abrasione rimangono in rilievo, creando un piacevole effetto in grado di far risaltare le venature naturali.

**SPIGOLO VIVO**

L'intero bordo perimetrale della faccia dell'elemento in legno viene realizzato a spigolo vivo; in tal modo durante la posa in opera degli elementi in legno è possibile ottenere una superficie piana senza soluzione di continuità.

**BISELLATO**

Lieve smusso praticato su tutto il perimetro della faccia dell'elemento in legno, il cui bordo risulta quindi leggermente ribassato; vengono così esaltate le dimensioni di ciascuno degli elementi che costituisce la pavimentazione.

CALIBRATED

The thickness of each single wooden element is calibrated with a precision of a hundredth of a millimetre. The uniform thickness in this way gained on all range of product is fundamental to obtain a perfectly smooth floor, without lipping between the various wooden elements.

BRUSHED

In this particular kind of treatment the face side of the wooden element is polished with special brushes, so that the areas of the element with higher abrasion resistance are raised and create a nice effect emphasizing the natural grain of the wood.

SHARP EDGE

The entire external edge of the wooden element face side is cut with a sharp edge; in this way during the laying of the floor it is possible to obtain a smooth even surface without any discontinuity.

MICRO-BEVELLED

The entire face perimeter of the wooden element has a light chamfer; the result of this finish is a slightly smoothed edge, which helps emphasizing the dimensions of each wooden element of the flooring.

KALIBRIERT

Die einzelnen Holzelemente werden in der Stärke mit hundertstel Millimeter Präzision gefertigt; diese Verarbeitung ermöglicht den Erhalt ein und der selben Stärke jeder Produktlinie, sodass ein absolut ebener Fußboden ohne Überzahn zwischen den einzelnen Holzelementen entsteht.

GEBÜRSTET

Bei dieser Verarbeitung wird die Oberfläche energisch mit eigens dafür vorgesehenen Bürsten behandelt; auf diese Art und Weise bleiben die härteren Holzpartien als Relief und bilden den schönen Effekt, die natürliche Holzfasern hervorzuheben.

SCHARFE KANTE

Alle Seitenkanten der Oberfläche des Holzelementes haben eine scharfe Kante; auf diese Weise kann man bei der Verlegung der Holzelemente eine glatte Oberfläche ohne Zwischenräume erhalten.

MIKRO-FASE

Leichte Abschrägung aller an der sichtbaren Oberfläche des Holzelementes befindlichen Kanten, die somit leicht vertieft sind; dadurch werden die Dimensionen jedes einzelnen Fußbodenelementes besonders hervorgehoben.

CALIBRÉE

Chaque élément en bois est fabriqué avec une précision au centième de millimètre au niveau de l'épaisseur ; cette fabrication permet d'obtenir des épaisseurs uniformes pour chaque ligne de produit, afin de réaliser un pavage plan, exempt de désaffleurement entre les différents éléments en bois.

BROSSÉE

Procédé de fabrication au moyen duquel des brosses dédiées sont appliquées avec vigueur sur la face de l'élément en bois; de cette façon, les zones les plus résistantes à l'abrasion restent en relief, créant ainsi un effet agréable qui fait ressortir les veinures naturelles.

ARÊTE VIVE

L'ensemble du bord du périmètre de la face de l'élément en bois est réalisé avec une arête vive ; de cette façon, lors de la pose des éléments en bois, il est possible d'obtenir une surface plane sans solutions de continuité.

BISEAUTÉE

Léger biseau réalisé sur tout le périmètre de la face de l'élément en bois, dont le bord est par conséquent abaissé ; les dimensions de chaque élément constituant le pavage sont ainsi mises en valeur.

Per le voci di capitolato consultare:

Item specifications see:

detaillierte Produktbeschreibung siehe:

Pour les spécifications des produits consulter:

www.aliparquets.com

C = COLORITURE - COLOURINGS - KOLORIERUNGEN - COLORATIONS



COLORITURA ARTIFICIALE DI SUPERFICIE

Alla sola faccia degli elementi in legno viene applicato un colore artificiale; tramite levigatura è possibile far riapparire la coloritura tipica della specie legnosa.



COLORITURA ARTIFICIALE FIBRA

La coloritura artificiale di superficie viene applicata alla sola venatura profonda degli elementi in legno; tramite levigatura è possibile far riapparire il colore tipico della specie legnosa.



COLORITURA ARTIFICIALE A TUTTO SPESSORE

Grazie ad un particolare processo di lavorazione gli elementi in legno vengono colorati a tutto spessore con pigmenti naturali. In questo modo è possibile conservare la colorazione anche dopo diverse levigature, mantenendo inalterate tutte le proprietà del legno massello.

ARTIFICIAL SURFACE COLOURING

An artificial colouring is applied only to the wooden element face side; the natural colour of the wood will reappear after sanding.

ARTIFICIAL COLOURING OF THE FIBRE

The surface artificial colouring is applied to the wooden element deep grain; the natural colour of the wood will reappear after sanding.

ARTIFICIAL COLOURING THROUGHOUT THE ENTIRE THICKNESS

With a special processing method, natural pigments are applied throughout the entire thickness of the wooden elements. In this way it is possible to preserve the colouring also after many sandings, while maintaining the natural properties of the solid wood.

KÜNSTLICHE FÄRBUNG DER OBERFLÄCHE

Hier erfolgt eine Oberflächenkolorierung nur auf der Oberseite der Elemente; durch eine anschließende Schleiftechnik erhält man die typische Färbung der Holzart.

KÜNSTLICHE FÄRBUNG DER FASER

Diese künstliche Oberflächenkolorierung wird nur in der Tiefenmaserung der Holzelemente vorgenommen; durch die anschließende Schleiftechnik wird die überschüssige Farbe abgetragen, sodass die natürliche Holzfarbe seiner Art zum Vorschein kommt und die künstliche Kolorierung lediglich in der Tiefenmaserung haften bleibt.

DURCH UND DURCH KÜNSTLICH GEFÄRBT

Dank eines besonderen Verfahrens werden die Holzelemente mit natürlichen Pigmenten durch und durch gefärbt. Auf diese Weise bleibt die Färbung auch nach mehreren Schleifvorgängen bestehen, ohne die Eigenschaften des Massivholzes zu verändern.

COLORATION ARTIFICIELLE DE SURFACE

Sur la face uniquement des éléments en bois, une couleur artificielle est appliquée ; il est possible de faire réapparaître par ponçage la couleur typique de l'espèce ligneuse.

COLORATION ARTIFICIELLE FIBRE

La coloration artificielle de surface est appliquée uniquement à la veinure profonde des éléments en bois ; il est possible de faire réapparaître par ponçage la couleur typique de l'espèce ligneuse.

COLORATION ARTIFICIELLE SUR TOUTE L'ÉPAISSEUR

Grâce à un processus particulier de fabrication, les éléments en bois sont colorés sur toute l'épaisseur avec des pigments naturels. De cette façon il est possible de conserver la coloration également après plusieurs ponçages, en préservant de manière inaltérée toutes les propriétés du bois massif.

F = FINITURE - FINISHES - OBERFLÄCHENVEREDLUNGEN - FINITIONS



VERNICE

- Effetto semilucido, finito con vernice ad alta resistenza. Consigliata per civili abitazioni.

- Semigloss finish with high-strength varnish top coat. Recommended for residential applications.

- Halbglanzeffekt - endbehandelt mit sehr widerstandsfähiger Beschichtung. Für Wohnbereiche empfohlen.

- Effet mi-brillant, finition par vernis à haute résistance. Conseillé pour habitations privées.



OPACA

- Effetto opaco, finito con vernice ad alta resistenza. Consigliata per civili abitazioni.

- Matt finish with high-strength varnish top coat. Recommended for residential applications.

- Extramatt, endbehandelt mit sehr widerstandsfähiger Beschichtung. Für Wohnbereiche empfohlen.

- Effet opaque, finition par vernis à haute résistance. Conseillé pour habitations privées.



HARD

- Effetto satinato ad alta resistenza all'usura, finito con vernici speciali antiscivolo. Consigliata per locali ad elevato calpestio.

- Hard-wearing satin finish, with special non-slip varnish top coat. Recommended for places where traffic is heavy.

- in Deutschland, Österreich und Schweiz nicht verfügbar

- Effet satiné hautement résistant à l'usure, finition par vernis spéciaux antidérapant. Conseillé pour locaux avec piétinement fréquent.



ASSENTE

- Assente

- Absent

- keine

- Absent